

Die Attachment

Fluid Dispensing

Global Vision . Worldwide Network . Local Presence .

The SPT Roth Group's strategy centers on developing the Company into an integrated global corporation. Over the last twenty years, we have built on our global vision and invested in building manufacturing and sales facilities strategically around the world to be close to our customers.

The worldwide network combined with excellent logistic facilities ensures prompt and full compliance with customer requirements including ship-to-stock or just-in-time delivery programs. Dedicated and highly qualified sales and service engineers and application specialists ensure that customers receive professional service and support at all times from the design phase to starting mass production.

SPT is open around the world, round the clock.



Pioneer . World Leader .

Small Precision Tools - SPT - is the pioneer and leader of semiconductor bonding tools for over three decades.

SPT is the only bonding tool manufacturer internationally established with marketing and production centres strategically positioned all over the globe, to be close to our customers.



1890
ROTH Group
Lyss, Switzerland



1964
Aprova Ltd.
Lyss, Switzerland



1974
Small Precision Tools Inc.
California, USA



1979
SPT Asia Pte Ltd.
Singapore



1982
Moldinject, Perfectamould AG.
Lyss, Switzerland



1991
Small Precision Tools (Phils.) Inc.
Manila, Philippines



1995
Small Precision Tools Co. Ltd.
Wuxi, China

2001
SPT Japan K.K.
Yokohama, Japan

Creative Solutions . Research & Development . Customer Partnership .

Customer partnership is our belief. At SPT, we listen to our customers. Because, every customer's needs are different, every solution is uniquely designed to satisfy those needs in the most effective way.

SPT offers a wide range of proactive support and services such as consulting, design, analysis, training seminars and benchmarking partnerships. SPT's material and process technology laboratories in Switzerland and Singapore offer technical support and services such as material analysis, process evaluation and characterization and tool design optimization.

Research



Development



Design



Partnership



Quality . Product & Service Excellence .

SPT is committed to quality and customer care. Our commitment to product excellence and continued support of our customers is part of the sustaining culture of SPT.

SPT's partnership philosophy has earned numerous prestigious awards and recognition from our customers.

Evaluation

Optimization

Precision

Technology

Training

Excellence

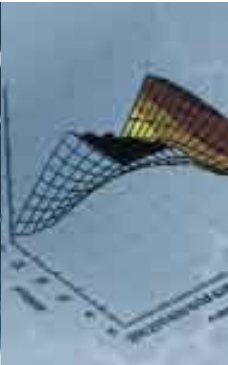

Product Technology . Excellence . Unsurpassed .

SPT positions itself as a progressive high-technology tool manufacturer using state-of-the-art processes. Our production capabilities range from conventional to CNC machining including milling, turning, surface grinding, honing, Electro-Discharge Machining or EDM, jig grinding and more. Our exclusive Injection Molding technology of small complex parts through SPT's own in-house formulation and sintering assures customers of the highest quality in high alumina ceramic and carbide materials.

Our equipment and manufacturing techniques are the most advanced in the ultra precision tool industry.

We make standard and custom designs for specific customer requirements. All tools meet the high precision dimensional and quality standards maintained by Small Precision Tools.

Bonding Capillary

μ BGA Tab Tool

Fine Pitch Bonding Wedge

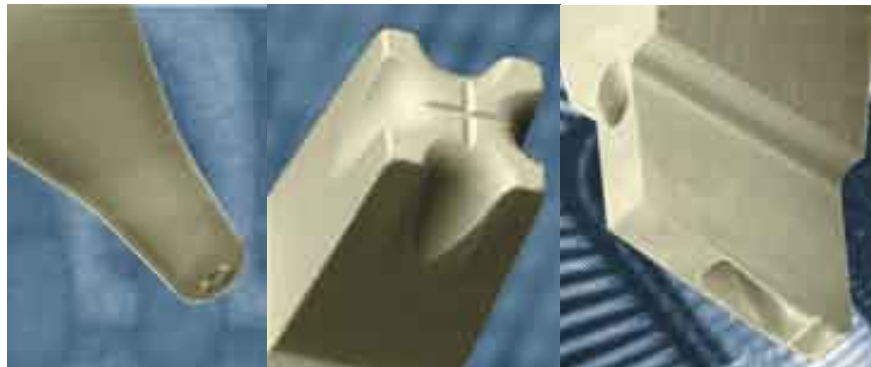

Waffle Tab Tool

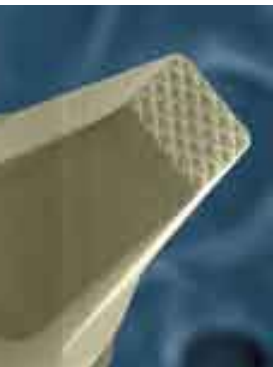

Die Attach Collets



Bushings



Precision Parts



CIM & MIM Parts



Watch Gear



CONTENTS

Die Bonding Tool Overview

10 Introduction











Pick-Up Tools

15 Pick-up Tool Introduction

16 Tool Material Selection

	19	Replaceable Tip Rubber.....	RTR/HRTR/HRTE
	22	Conical Tip Rubber.....	CTR/HCTR/HCTE
	23	Rectangular Tip Rubber With Cross-Groove.....	RTR-D3(D2)-CG
	24	Pure Conical Tip Rubber	PCTR/FCTR/BPCT
	26	Suction Cup.....	SC
	26	High Temperature Suction Cup	HSC
	27	Replaceable Plastic Conical Tip.....	RPCT
	28	Replaceable Cylindrical Silicone Tip	ST
	29	Threaded Replaceable Conical Tip	2151-CT
	30	Conical Tip	CT
	31	Rectangular Tip.....	RT
	32	Peripheral Pick-up Tool	PL
	33	Die Collet Introduction	
	34	4 Sided Inverted Pyramid Die Collet	IP, IPIR, IPNC,IPCR
	35	2 Sided Inverted Pyramid Die Collet	CH
	37	Compliant Tools	

Dispensing And Stamping Tools

	38	Fluid Dispensing Introduction	
	39	Dispensing & Stamping Tools Introduction	
	40	Epoxy Dispensing Tools	EDT
	41	EDT Bodies	
	42	How To Order – EDT	
	43	Programmable Dispensing Tools	
	43	Common Dispensing Nozzle	CDN
	44	Micro Dispensing Nozzle.....	MDN
	45	MDN Luer Lock	MDN
	46	Luer Dispensing Nozzle	LDN
	47	Epoxy Dispensing Nozzle	EDN
	48	Stamping Tool Introduction	
	49	Rubber Epoxy Stamping Tools.....	REST
	50	Steel Epoxy Stamping Tools	SEST
Accessories			
	52	Push-up Needles.....	PUN
	53	Die Shear Tool.....	DST
	54	Spanking Tool.....	SPANK
	55	Needle Cap & Needle Holder.....	NC, NH

Shank Styles Used On Common Die Attach Bonders

56	Shank Styles 2101, 2102, 2102A1, 2102M2, 2112, 2143, 2134
58	Shank Styles 2138, 2138G, 2141, 2141M, GS, HG1/HG2
60	Shank Styles TSK, 044C, 574/574A, 1059/1059D, MC, MC26/ MC26A
62	Shank Styles MC26AR, DBH3, VW, GSM
64	Die Bonding Tools Design Enquiry Form

We reserve the right to make changes to design or specifications at any time without notice.

DIE BONDING TOOL OVERVIEW

Introduction

The assembly of a semiconductor die into a package or onto a substrate requires a dedicated machine so-called "Die Bonder". Each equipment is normally delivered with its set of selected tools used for die handling and epoxy dispensing. Depending on the applications, the tool may have a very strong impact on the process reliability and productivity. Therefore, the tool must be tailored to give its best performance and match exactly the tight requirements set by a specific given situation.

Basic Process Steps

By focusing the assembly steps to the processes related to the die handling, we can distinguish the 4 following phases :

1. The selected Pick-up tool approaches the die.
2. A needle pushes the die against the PUT surface.
3. The tool transfers the die onto the substrate.
4. The tool releases the die on bond position.



In parallel to these steps, an adhesive will be dispensed or stamped on the substrate prior to die placement.

Die Ejection

Once a die has been singulated from a wafer (usually by sawing), it may be presented to the next process step in different forms. If the die still resides on the frame used for sawing, the die must be picked up from the tacky tape. To help the die break the adhesion force to the tape, one or more needles are gently pushing against the back side of the die during the lift phase. Simultaneously, a pick-up tool (PUT) will collect the die by vacuum and transfer it to the next station.

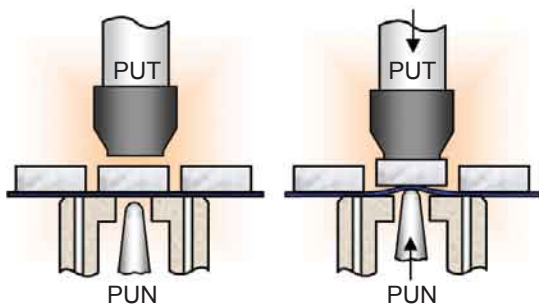

The Push-Up Needle (PUN) is part of an assembly including the needle holder and a cap, also called pepper pot. This one has a middle hole through which the needle will have access to the tape. A few other vacuum holes are on the periphery and used to hold the tape down during the stretching caused by the upward movement of the needle. The needle has traditionally an outer diameter



of 0.70 mm or eventually 0.6mm. The standard tip profile is a sphere of various radiuses. As option, the tip may contain a flat or a relative bigger radius so as to avoid punching through the thin tape. The material of PUN is tungsten carbide but recently HSS has found also acceptance. Softer tip material like plastic still represents a marginal solution.

Die Pick-Up

Despite some developments or original ideas for exotic pick-up techniques, in effective production environment, the die is almost exclusively lifted with vacuum force by touching the die on its surface or on the edges.

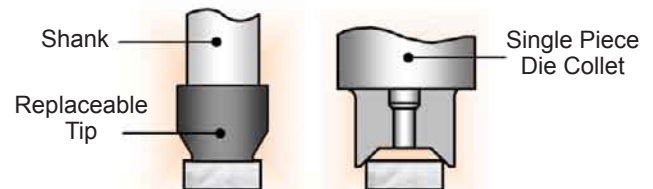

The selection of tool shape and material is made based on several criteria which includes mainly :

- The size and shape of the die which restricts the choice of material due to manufacturability limitations or process complication like ultra-thin die.
- Topology of the die surface like presence of bumps for flip chip or of a fragile membrane.
- Process temperature requiring high temp resistance rubber, plastic or other metallic tools.
- Other mechanical or electrical properties of the tool material like wear, ESD safe, hardness, color.
- Economical considerations due to tool life-time, replaceable tip or single piece construction.
- Special requirement like compliant tip with flexible parallelism adjustment.

The Selection of a Pick-Up Tool

Based on the application, there may be sometimes many different types of tool susceptible to fulfill the requirements. In that case, the recommendation is to select a rather standard and simple tool which may be quickly available and which price is also advantageous. In this category, we find all the replaceable tip materials like thermoplastic, rubber and some of the plastics. A good alternative is the two-piece assembly of a steel shank, dedicated to the die bonder, and an inserted or glued plastic tip. The semiconductor industry has since a long time given preferences to specific materials which are today very popular and widely spread. For the rubbers, NBR and Silicone Rubber while for the plastics, the most used are Vespel ©, Delrin ©, Torton ©. The experience has shown that it is always possible to improve and optimize the performance of a tool. This is made possible through the development of custom tool design and careful selection of a more appropriate material. The assistance of an experienced partner with a long tool manufacturing history may be here particularly helpful.



Pick-up Tool Shank Styles

Each tool tip is adapted to a shank which is compatible with a corresponding Die Bonder Head adaptor. The diversity of shanks is therefore quite large even if

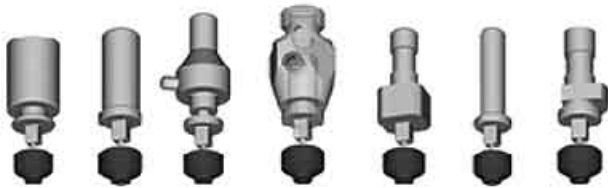

many OEMs have selected what has almost become a standard : a cylinder Ø 3.175mm. For the replaceable elastomer family tips, the size of the square insert formed on the backside of the tip is the same for the major tool suppliers.

Pick-up Tool Categories

Each tool has advantages and drawbacks. The ideal universal tool does not exist, there are always some compromises to make for each application. Each tool stoke will have a certain interaction with the contacted area of the die. A too hard material can deform some die structures or leave scratches if the face is not well

polished. A soft material will pick-up some silicon debris and mark systematically each subsequent picked-up die. Let's take a die and compare the performance of different tools based on the contact surface (shown in transparent blue).

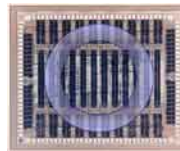

The Conical Tip is available from the softest to the hardest of material. One tool can be used for several die sizes. For high ratio length/width die, the vacuum force is limited with a risk of die rotation. Depending on the material, very tiny tips, well under the current smallest die size, are available.



The Rectangular Tip is more adapted to a non -square die size. The force is distributed over a larger surface, thus reducing the pressure in comparison to the CT. This tool may have more than one vacuum hole on the front or eventually placed off-center. For harder material, the perpendicularity and flatness is an important parameter. Very accurate and reproducible tools are required.

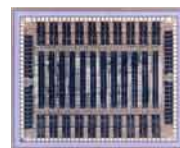

The Peripheral Tip is used to when we want to avoid contact with an active area. This tool is also good when the center of die is not flat, per example with the presence of bumps or multi-chip module. This design maximizes the pick-up tool vacuum force.

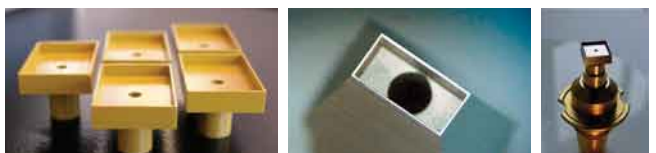

DIE BONDING TOOL OVERVIEW



The Die Collet holds the die on the edges. This tool is made in tungsten carbide, the inner inverted pyramid walls will help self-centering the die during the pick-up phase. This geometry allows a scrubbing action, necessary for eutectic alloy die attach option. Die collet may have only 2 walls contacting the die, the other two sides being open. There is certainly a vacuum loss in that case but the force is still enough to hold the die without any consequences.

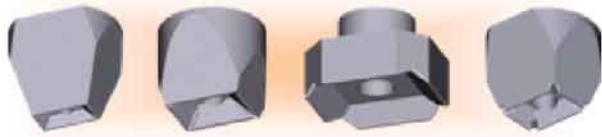

We find different options for the die collet face depending on the way the die corners relieves have been shaped. See below examples.



Special Applications

Beside the very large majority of situations where the above reviewed tools will find acceptance, there are always cases requiring special features. For example, we can mention the Flip Chip or bumped device as well as ultra thin Die (thickness <math>< 70\mu\text{m}</math>).

Flip Chip Pick-Up Tools

There are different assembly techniques used to assemble a flip chip. We can distinguish the following 4 processes illustrated hereafter :

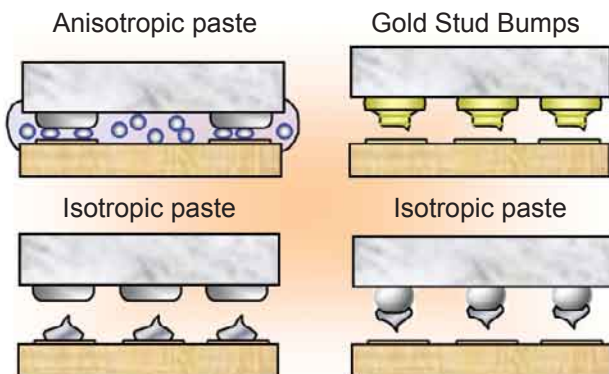

The handling of the flip chip during placement is possible with many different tools because the backside of the die offers a surface without special requirement. The only concern is to care for the material compatibility in terms of heat resistance and conductivity. In contrast, the Gold Stud Bumps solution may need a die collet type if the assembly is made through thermosonic process. It is desired that the chip be parallel to the substrate pads. If the tool is made with a flexible tip, the die will be dynamically adjusted to the pad level.



Before a die is presented to a flip station, it has to be pick-up from the bumped side. The tool may be made or selected in order to avoid touching the bumps. When this is not possible, the best choice is to use a very soft material minimizing vacuum leaks.



Thin Die Pick-Up Tools

Any vacuum cavity will have the tendency to warp a thin die. Therefore, traditional PUT are not adequate. A few designs are being used with more or less success. We are showing a few solutions hereafter:



Fluid Dispensing Introduction

Before placing a die on a substrate, a die attach method has been selected. Based on the device application, we distinguish 5 different techniques :

- 1) Epoxy or any adhesive paste die attach
- 2) Soft-solder die attach
- 3) Eutectic die attach
- 4) Flip Chip die attach
- 5) Die Back Side tape/adhesive coating

We will only focus on the 2 first categories which require specific dispensing or stamping tools.

Stamping Process

The epoxy stamping is a rather old technique to apply an adhesive paste on a substrate. Due to the continuous search in improving productivity and throughput, stamping has recently gained more consideration.

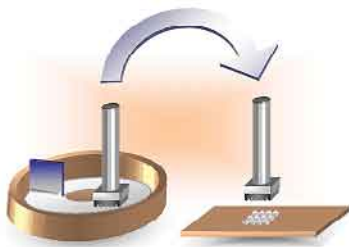

The paste is placed into a rotating cup or plate which surface is leveled by a blade set at the required height, typically 0.3mm. During the dipping, the tool will collect an amount of paste which depends on the tool geometry, the speed, the height of epoxy layer and on the viscosity and thixotropy of the paste. During stamping, a portion of the collected paste will wet and stick on the target. There are multiple stamping tool designs used to cover the die size range. A few are here illustrated :

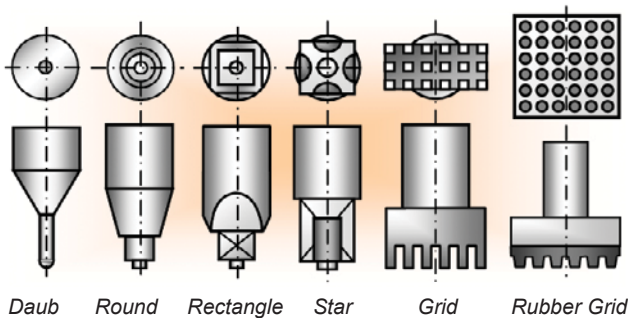

The material is usually stainless steel or rubber pad for the last one. Occasionally, a tool is made in tungsten carbide. Other tip configurations are seen in production floor like : Frame, Ring, Fork etc.

Stamping Recommendations

The stamping results are not easy to anticipate as there are a lot of factors coming into play during the process. By following some guidelines, we can approach the desired results. Optimization is usually reached by bond head stamping parameter adjustments or tool dimensions tuning. The ability of the epoxy paste to wet the back side of the die after placement will also help



to compensate small defects. The example below is showing the epoxy stamping layout of a STAR tool 4x2mm. After placement, the epoxy does first not cover completely the



die but after a few minutes it slowly expands through capillary effect. The last picture is showing the die from the top after curing. The wetting has covered 100% of the die surface with

no excess of fillet on the four sides. We propose the following recommendations concerning the choice of tool based on the die size and a viscosity of 6000-12000 cps to be considered as medium :

Die Size	Tools
< 0.3mm	DAUB
< 0.8mm	ROUND
< 7x7mm	STAR
> 7x7mm	GRID (steel or rubber)

The optimum size of the stamping tool is a priori not easy to define due to the many variables involved in the process. What complicates further the selection is the non linearity of the any formula related to the die size or ratio and paste viscosity.

Another problem is the limited quantity of paste that can be collected by a tool to allow one stamping cycle and get enough epoxy Bond Line Thickness. This is particular problematic for large die sizes using the GRID tool type or other SEST where a Stand Off Pin is not present or not possible to manufacture.

Nozzle or Needle Dispensing Tools

In this method, time and pressure is commonly used to push the fluid through a needle or nozzle to form single dot/line or multiple dot/line patterns over a substrate. Over the years, various dispensing platforms such as Auger and piston have been developed. We distinguish 2 different techniques depending on the dispensing accuracy and equipment capability :

- Static Dispensing
- Programmable Dispensing

Static Dispensing Tools

The advantage of these tools in comparison to the programmable dispensing tools is the throughput. In one shot, a defined pattern is quickly generated and the volume dispensed is finely adjustable on the pump/valve setting parameters. The epoxy paste is dispensing through needles or through a nozzle having usually a cross groove on the face.



The body of the tool is to be adapted to a specific die bonder type or directly to a standard syringe.

Programmable Dispensing Tools

The nozzle or needle tip is used as a written pen to dispense a specific epoxy pattern. The layout and necessary dispensed volume is calculated on the die bonders, based on the die size and desired bond line thickness. A few examples are shown hereafter



From left to right : Cross, Double Y and Asterisk

The valid size range for the Cross layout can extend from 2 to 25mm for square dice. For smaller dimensions, single dots are dispensed. The nozzles are also used to dispense volume of material like glob top and flip chip underfill.

Nozzle Types

Even if the traditional single needle with plastic holder is quite popular, the nozzle construction is more sophisticated and gives better results due to a wiser inner tapered hole. The nozzle outer geometry is here again dependent on the equipment on which it is mounted. Some



types are more common and are compatible on different dispenser types. This is the more the case in the Surface Mount Technology rather than in the Die Bonder field.

The Luer Lock thread allows the nozzle to be directly connected to a common syringe tip. The material of the nozzle or needle was for a long time restricted to stainless steel. However, with the dot size shrinkage requirement, alternative material needed to be developed especially for hole diameters of 0.15mm and below.



The ceramic is the material of choice for those applications especially if the inner hole is molded and well polished. The advantages are longer tool life, reduction of paste clogging as well as ease of cleaning and improved fluid flow. The soft solder dispensing is made with comparable nozzle technique or through a process known as “spanking”.



Here, the solder is melted from a wire and dispensed on the target. The Spank tool, with a shallow front cavity, is placed over the solder volume and defines a specific wetted area.



Conclusion

You have seen a short description of many different tools to handle a device and dispense a fluid. Each process and application offers a wide range of possibilities in the selection of an appropriate tool. Due to the large range of base materials as well as options in the finishing of the tools, there is almost an infinite performance behavior. Fortunately, most of them will comply to the standard requirement and give satisfaction to the user. In other more stringent situations, a more focused approach need to be implemented. The best results are then obtained by working closely with a partner able and willing to support his customer in the search of excellence.

PICK UP TOOLS - INTRODUCTION

A tool designed to pick-up, hold, transfer and place a die on a substrate or leadframe.

The tool is composed of a body, called shank, adapted to a specific die bonder or pick & place equipment, and a tip making the physical contact with the die.



Pick-Up Tool Categories

Replaceable Pick-up Tip to be inserted on a separate steel shank.

- **RTR / CTR** Rubber Tip
- **HRTR / HCTR** High Temp Rubber Tip
- **HRTE / HCTE** High Temp Elastomer Tip
- **HRTR / HCTR** High Temp Rubber Tip
- **BPCT / PCTR** Thermoplastic Elastomer Tip
- **SC** Suction Cup
- **HSC** High Temp Suction Cup
- **RPCT** Delrin Conical Tip
- **ST** Silicone Tip

Single or Two Piece construction.

The tip is directly build into the shank body material or pressed into the shank.

- **CT** Conical Tip
- **RT** Rectangular Tip
- **PL** Peripheral Tip
- **IP / IPIR / IPNC / IPCR / CH** Die collet

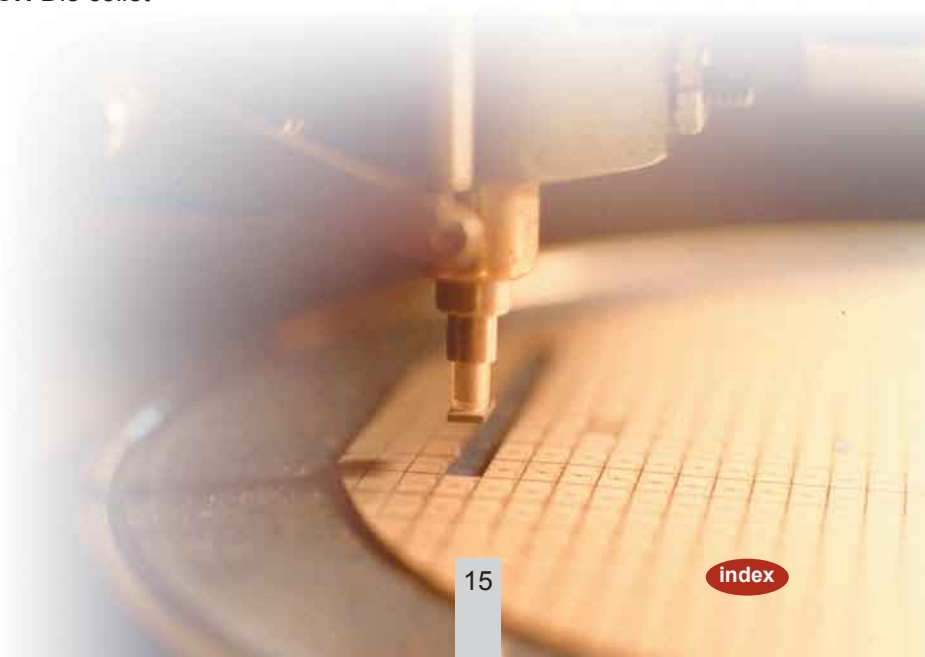

TOOL MATERIAL SELECTION

What is the right material for a particular tool or application? Mechanical, thermal and electrical properties of a material have to be compatible with the process and requirements during the die attach assembly step. The choice of material is infinite. However, there are a few which have been established as base material for years and are known by engineers and recommended by most tool suppliers. SPT continuously investigates and makes trials with alternative materials and concepts. Please, consult SPT sales office or personnel for our wide range of available materials to fit your needs. Cost of less common plastics (*) may be higher than other standard plastics.

Available Materials Definition & Description

Color / Code	Name	Hardness	Resistivity Range	Max Temp	Available for Tool Type
○ C	Ceramic Al ₂ O ₃	2000 HV10	Insulative	>500°C	CT, RT
● W	Tungsten carbide	1700 HV10	Conductive	500°C	Collets , PL, CT, RT
○ SS	Stainless Steel	160 HB30	Conductive	>500°C	Shanks , PL
● P01	PBI *	Rockwell E105	Insulative	310°C	Consult nearest SPT office
● TORS	Torlon ESD safe	Rockwell E90	Dissipative	270°C	CT, RT, 2151-CT, RPCT, PL
● TOR	Torlon Polyamide-imide (PAI)	Rockwell E86	Insulative	250°C	CT, RT, 2151-CT, RPCT, PL
● HTV	Vespel Polyimide (PI) SP01	Rockwell E52	Insulative	240°C	CT, RT, 2151-CT, RPCT, PL
● HTV21	Vespel Polyimide (PI) SP21	Rockwell E35	Dissipative	250°C	CT, RT, 2151-CT, RPCT, PL
● P03	PEI *	Rockwell M115	Dissipative	170°C	Consult nearest SPT office
● P02	PEEK *	Rockwell M95	Dissipative	250°C	Consult nearest SPT office
○ DEL	Delrin (POM)	Rockwell M92	Insulative	135°C	CT, RT, 2151-CT, RPCT, PL
● PES	Polyethersulfone *	Rockwell M87	Dissipative	170°C	Consult nearest SPT office
● DELS	Delrin (POM) ESD safe	Rockwell M74	Dissipative	90°C	CT, RT, 2151-CT, RPCT, PL
● P06	PTFE *	Rockwell M35	Conductive	260°C	Consult nearest SPT office
● NBR	Nitrile rubber (NBR)	88 Shore A	Dissipative	100°C	RTR , CTR , SC, RT, PL
○ 74A	Thermoplastic elastomer	88 Shore A	Dissipative	135°C	PCTR / PRTR
● 74AB	Thermoplastic elastomer	88 Shore A	Dissipative	135°C	BPCT / BPRT
● SR	Silicone rubber	86 Shore A	Dissipative	250°C	HRTR , HCTR
● FKM	Fluoroelastomer	70 Shore A	Dissipative	250°C	HRTE , HCTE, RT, PL
○ SIL	Silicone rubber	55 Shore A	Insulative	200°C	ST
● SR	Silicone rubber	50 Shore A	Conductive	230°C	HSC
○ 98	Thermoplastic elastomer	45 Shore A	Dissipative	100°C	FCTR / FRTR

Ceramic (Al₂O₃) is a very pure white/creamy aluminum oxide (99.9%) base material used in molding injection and sintering process.

The Pick Up Tools made in Ceramic benefit from the SPT capillary manufacturing technology. Very small vacuum holes capability, low thermal conductivity and density make Ceramic an alternative to Tungsten carbide in small die size handling.

Ceramic tools are usually composed of a ceramic tip inserted or glued into a stainless steel shank.

Tungsten carbide (WC) is a hard metallic material composed of approximately a 1:1 ratio of tungsten and carbon atoms. For practical use, it is alloyed with a few % of a softer and strength metal, usually cobalt mixed during powder metallurgy including also milling, pressing and sintering. Carbides are generally classified based on the binder content and grain size. WC is widely used because of its extraordinary properties particularly suited to wear resistant tools. Combined with thermal resistance and electrical conductive characteristics, WC is the material of choice in many applications.

Finishing processes like grinding, EDM & polishing give WC an excellent surface quality and very accurate dimension control.

SS Stainless Steel is resistance against corrosion due to its content of chrome (min 12%) which creates a passive protective layer on the surface of oxidizing steels. Performance of SS is improved by addition of alloy like Nickel & Molybdenum.

Torlon® (Trademark from Dupont) is a yellow-ochre Poly(amide-imide) resin. High impact strength, exceptional mechanical strength and excellent retention of these properties in high temperature environments, characterize all Torlon resins. Torlon parts can provide equivalent stiffness compared to metals but at significantly lower weight. This material comes in several extruded rod diameters.

VespeI® (Trademark from Amoco) is a condensation type. Vespel has no observable glass transition temperature or melting point below the decomposition temperature that is well in excess of 400°C. This material is available in several compositions and some grades contain fillers to enhance properties like graphite for the black SP21 in order to increase wear resistance and reduce electrical resistance. The standard brown grade SP1 has excellent strength with low modulus and thermal conductivity.

Delrin® (Trademark from Dupont) is a crystalline plastic made by the polymerization of formaldehyde. Also known under POM (Polyoxymethylene) or Polyacetal Homopolymer or just acetal resin. Delrin has a high tensile strength, impact, fatigue and creep resistance as well as excellent dimensional stability and low friction. SPT uses either rods or granulate base material to either machine or mold inject white Delrin parts.

PES or PolyEtherSulfone is a high temperature engineering amorphous thermoplastic with anti-static properties. It is a tough material having tensile and impact strengths, with excellent dimensional stability.

PTFE is a high temperature engineering amorphous thermoplastic with anti-static properties. The very low friction coefficient makes PTFE an excellent candidate for no stick applications.

Nitrile Rubber (NBR) is a black Butadiene-Acrylonitrile Rubber specially mixed with graphite fiber to enhance electrostatic discharge. The base material is injected into molds to form different blank sizes which, after vulcanization and other thermal processes, are ground to the desired external dimensions. For large PL or RT tools, the base material is a sheet.

Silicone Rubber (MVQ) is the alternative to the Nitrile rubber for high temperature applications. The manufacturing flow is similar to NBR: The black base material is injected into molds to form different blank sizes which, after vulcanization and other thermal processes, are ground to the desired external dimensions.

Thermoplastic Elastomer 74A has been developed by SPT to improve performance of NBR and to have a finished shape after the mold injection process. Granulates are mixed with anti-static additive prior to compounding and injection. This translucent material is a result of a combination between the properties of thermoplastics and rubbers. The thermoplastic elastomer material is also available in black color (74AB).

Thermoplastic Elastomer 98 has been developed in SPT to propose a very soft material for handling of non-flat die surfaces and especially bumped die. Granulates are mixed with anti-static additive prior to injection. This white material is a result of a combination between the properties of thermoplastics and rubbers.

Silicone Rubber is produced in small tubes cut to the right length. This transparent material is soft with a good resistance to high temperature and due to its geometry, uses only a very limited space.

TOOL SELECTION CRITERIA

Temperature resistance of material must match process temperature. The given temperature is valid for continuous operation while peak with higher value may be allowed by intermittence for materials other than rubbers.

Material wear or fatigue is more pronounced when working at temperature close to the limit.

Hardness is a guarantee of the longevity of a tool but this one becomes also more fragile. Softer material will compensate for uneven substrate surfaces. Damage on the die surface is prevented with rubber/silicone/elastomer material at the condition that those do not pick-up debris of chipping being trapped into the material matrix.

Sensitive devices may be handled also by very hard material at the condition that the tool contact surface is well polished and does not exhibit sharp edges and that the tool is operated on a automatic or precise die bonder.

Rockwell hardness testing is a general method for measuring the bulk hardness of metallic and polymer materials. Although hardness testing does not give a direct measurement of any performance properties, hardness correlates with strength, wear resistance, and other properties. The Rockwell method measures the permanent depth of indentation produced by a force on an indenter.

There are separate scales for ferrous metals, nonferrous metals, and plastics. Common Rockwell hardness scales include B and C for metals and E, M and R for polymers.

Each scale range uses a defined steel ball diameter (or sphero-conical diamond) and load. A material can be expressed in more than one scale range but for comparison or conversion purposes it is recommended to consider values from the same scale.

Example: hardness of DELS is M74 or R109. Symbol M uses a ¼" ball at 100 kgf while symbol R uses a ½" ball at 60 kgf. The value after the symbol is proportional to the hardness for its relative scale.

Electrical properties are usually limited to the ability of a material to sustain Electro Static Discharge susceptible to damage the IC. However, many highly resistive material are used since decades without reporting any damage. Today, we can find ESD safe version for all standard plastic material. The electrical properties of material are given in different units like surface resistivity, surface resistance, volume resistance or static decay time leading sometimes to misunderstanding and confusion. Per example, this is the Surface resistivity range per EIA-541:

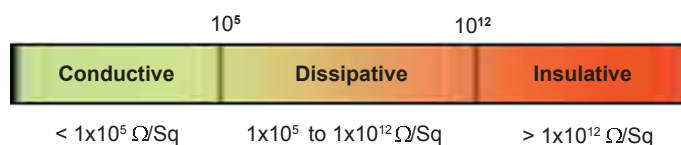

Tool size limits the choice of available material and is practically restricted to WC for very small and complicated shapes. With the advent of ultra-small die, Ceramic, as pick-up material, has found an increased interest.

Price & Lifetime are other 2 related criteria for material selection. Replaceable tips are found in the lower cost range and are mainly composed of soft material like rubbers & elastomers at the exception of Delrin RPCT. The other plastics are assembled on a stainless-steel shank resulting in a single piece tool. WC tools are more expensive especially if EDM is necessary for the tool manufacturing but the lifetime is also significantly higher.

RTR: RECTANGULAR TIP RUBBER
CTR: CONICAL TIP RUBBER

HRTR: HIGH TEMPERATURE RECTANGULAR TIP RUBBER
HCTR: HIGH TEMPERATURE CONICAL TIP RUBBER

HRTE: HIGH TEMPERATURE RECTANGULAR TIP ELASTOMER
HCTE: HIGH TEMPERATURE CONICAL TIP ELASTOMER

This black rubber is widely used and very popular for die surface pick-up. The large range of available sizes offers an economic and flexible solution for pick and place operation. To be used with square stud shanks, the tip remains well aligned and allows quick set-up time.

Features RTR / CTR

- Nitrile Rubber (88 ShA) resistant up to 100°C
- Custom rectangular / conical shape
- Static Dissipative



Features HRTR / HCTR

- Silicone Rubber (86 ShA) resistant up to 250°C
- Custom rectangular / conical shape
- Static Dissipative

Features HRTE / HCTE

- Elastomer 70 Shore A
- Resistant up to 250°C
- Matte Contact Surface for Type A
- Static Dissipative
- Available for Type A & B



The external rubber tip size is distributed into 4 possible dimension sets A, B, C and D, while the corresponding square insert may have only 2 different sizes Insert A/B & C/D. Vertical Relief (VR) is standard where applicable and ranges from .002" / 0.050mm to .015" / 0.380mm depending on the tip size.

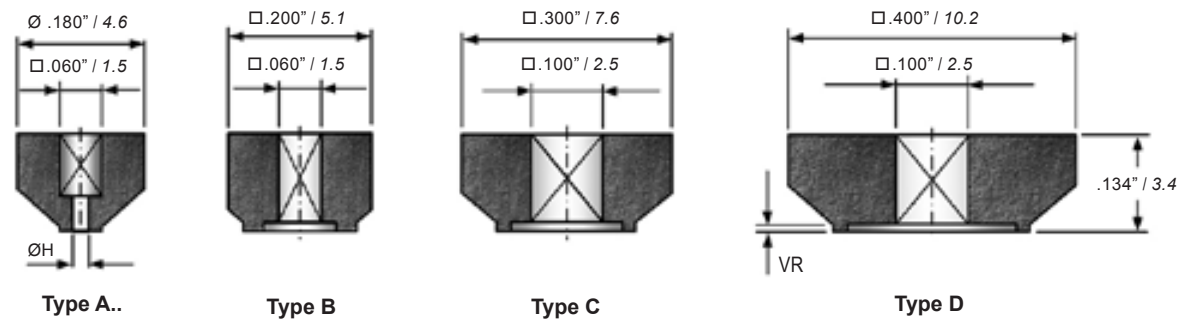

- A1.. ØH = .035" / 0.89
 - A2.. ØH = .025" / 0.63
 - A3.. ØH = .015" / 0.38
 - A4.. ØH = .010" / 0.25
 - A5.. ØH = .008" / 0.20
 - A6.. ØH = .006" / 0.15
- For round (ØF) and square (TL=TW) face geometry from size .080" / 2.03mm and above the countersunk option is available on request This option decreases the tip contact area and improves vacuum force.
- Standard WT = .010" / 0.25mm or bigger upon specific request.

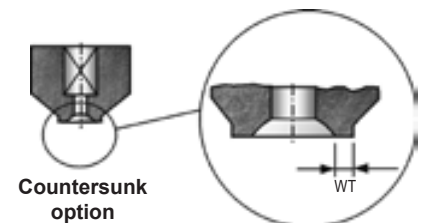

RTR / HRTR / HRTE TYPE A & B – RECTANGULAR TIP RUBBER

	Tip Type	TL x TW inch / mm	ØH / CL x CW inch / mm	Shank Insert Type
Square Face	RTR/HRTR/HRTE - A6- 012 x 012	.012 x .012 / 0.30 x 0.30	.006 / 0.15	A/B
	RTR/HRTR/HRTE - A5- 015 x 015	.015 x .015 / 0.38 x 0.38	.008 / 0.20	A/B
	RTR/HRTR/HRTE - A4- 020 x 020	.020 x .020 / 0.51 x 0.51	.010 / 0.25	A/B
	RTR/HRTR/HRTE - A3- 025 x 025	.025 x .025 / 0.63 x 0.63	.015 / 0.38	A/B
	RTR/HRTR/HRTE - A3- 030 x 030	.030 x .030 / 0.76 x 0.76	.015 / 0.38	A/B
	RTR/HRTR/HRTE - A3- 035 x 035	.035 x .035 / 0.89 x 0.89	.015 / 0.38	A/B
	RTR/HRTR/HRTE - A3- 040 x 040	.040 x .040 / 1.02 x 1.02	.015 / 0.38	A/B
	RTR/HRTR/HRTE - A2- 045 x 045	.045 x .045 / 1.14 x 1.14	.025 / 0.63	A/B
	RTR/HRTR/HRTE - A2- 050 x 050	.050 x .050 / 1.27 x 1.27	.025 / 0.63	A/B
	RTR/HRTR/HRTE - A1- 060 x 060	.060 x .060 / 1.52 x 1.52	.035 / 0.89	A/B
	RTR/HRTR/HRTE - A1- 070 x 070	.070 x .070 / 1.78 x 1.78	.035 / 0.89	A/B
	RTR/HRTR/HRTE - A1- 080 x 080	.080 x .080 / 2.03 x 2.03	.035 / 0.89	A/B
	RTR/HRTR/HRTE - A1- 090 x 090	.090 x .090 / 2.29 x 2.29	.035 / 0.89	A/B
	RTR/HRTR/HRTE - A1- 100 x 100	.100 x .100 / 2.54 x 2.54	.035 / 0.89	A/B
	RTR/HRTR/HRTE - A1- 120 x 120	.120 x .120 / 3.05 x 3.05	.035 / 0.89	A/B
RTR/HRTR/HRTE - A3- 060 x 030	.060 x .030 / 1.52 x 0.76	.015 / 0.38	A/B	
RTR/HRTR/HRTE - A3- 070 x 035	.070 x .035 / 1.78 x 0.89	.015 / 0.38	A/B	
RTR/HRTR/HRTE - A2- 080 x 040	.080 x .040 / 2.03 x 1.02	.025 / 0.63	A/B	
RTR/HRTR/HRTE - A2- 090 x 045	.090 x .045 / 2.29 x 1.14	.025 / 0.63	A/B	
RTR/HRTR/HRTE - A2- 100 x 050	.100 x .050 / 2.54 x 1.27	.025 / 0.63	A/B	
RTR/HRTR/HRTE - A1- 110 x 055	.110 x .055 / 2.79 x 1.40	.035 / 0.89	A/B	
RTR/HRTR/HRTE - A1- 120 x 060	.120 x .060 / 3.05 x 1.52	.035 / 0.89	A/B	
RTR/HRTR/HRTE - A1- 130 x 065	.130 x .065 / 3.30 x 1.65	.035 / 0.89	A/B	
Square Face	RTR/HRTR/HRTE - B - 120 x 120	.120 x .120 / 3.05 x 3.05	.100 x .060 / 2.54 x 1.52	A/B
	RTR/HRTR/HRTE - B - 130 x 130	.130 x .130 / 3.30 x 3.30	.100 x .060 / 2.54 x 1.52	A/B
	RTR/HRTR/HRTE - B - 140 x 140	.140 x .140 / 3.56 x 3.56	.100 x .060 / 2.54 x 1.52	A/B
	RTR/HRTR/HRTE - B - 150 x 150	.150 x .150 / 3.81 x 3.81	.100 x .060 / 2.54 x 1.52	A/B
	RTR/HRTR/HRTE - B - 160 x 160	.160 x .160 / 4.06 x 4.06	.100 x .060 / 2.54 x 1.52	A/B
	RTR/HRTR/HRTE - B - 170 x 170	.170 x .170 / 4.32 x 4.32	.100 x .060 / 2.54 x 1.52	A/B
	RTR/HRTR/HRTE - B - 180 x 180	.180 x .180 / 4.57 x 4.57	.100 x .060 / 2.54 x 1.52	A/B
	RTR/HRTR/HRTE - B - 190 x 190	.190 x .190 / 4.83 x 4.83	.100 x .060 / 2.54 x 1.52	A/B
	RTR/HRTR/HRTE - B - 200 x 200	.200 x .200 / 5.08 x 5.08	.100 x .060 / 2.54 x 1.52	A/B
	RTR/HRTR/HRTE - B - 120 x 080	.120 x .080 / 3.05 x 2.03	.100 x .060 / 2.54 x 1.52	A/B
	RTR/HRTR/HRTE - B - 140 x 090	.140 x .090 / 3.56 x 2.29	.100 x .060 / 2.54 x 1.52	A/B
	RTR/HRTR/HRTE - B - 160 x 100	.160 x .100 / 4.06 x 2.54	.100 x .060 / 2.54 x 1.52	A/B
	RTR/HRTR/HRTE - B - 180 x 120	.180 x .120 / 4.57 x 3.05	.100 x .060 / 2.54 x 1.52	A/B
	RTR/HRTR/HRTE - B - 200 x 140	.200 x .140 / 5.08 x 3.56	.100 x .060 / 2.54 x 1.52	A/B

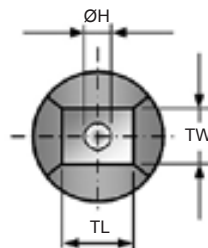

Type A

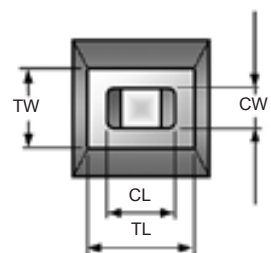

Type B

RTR / HRTR TYPE C & D - RECTANGULAR TIP RUBBER

	Tip Type	TL x TW inch / mm	CL x CW inch / mm	Shank Insert Type
Square Face	RTR/HRTR - C - 180 x 180	.180 x .180 / 4.57 x 4.57	.160 x .100 / 4.06 x 2.54	C/D
	RTR/HRTR - C - 190 x 190	.190 x .190 / 4.83 x 4.83	.160 x .100 / 4.06 x 2.54	C/D
	RTR/HRTR - C - 200 x 200	.200 x .200 / 5.08 x 5.08	.160 x .100 / 4.06 x 2.54	C/D
	RTR/HRTR - C - 220 x 220	.220 x .220 / 5.59 x 5.59	.160 x .100 / 4.06 x 2.54	C/D
	RTR/HRTR - C - 240 x 240	.240 x .240 / 6.10 x 6.10	.160 x .100 / 4.06 x 2.54	C/D
	RTR/HRTR - C - 260 x 260	.260 x .260 / 6.60 x 6.60	.160 x .100 / 4.06 x 2.54	C/D
	RTR/HRTR - C - 280 x 280	.280 x .280 / 7.11 x 7.11	.160 x .100 / 4.06 x 2.54	C/D
	RTR/HRTR - C - 300 x 300	.300 x .300 / 7.62 x 7.62	.160 x .100 / 4.06 x 2.54	C/D
Square Face	RTR/HRTR - C - 180 x 120	.180 x .120 / 4.57 x 3.05	.160 x .100 / 4.06 x 2.54	C/D
	RTR/HRTR - C - 200 x 130	.200 x .130 / 5.08 x 3.30	.160 x .100 / 4.06 x 2.54	C/D
	RTR/HRTR - C - 220 x 140	.220 x .140 / 5.59 x 3.56	.160 x .100 / 4.06 x 2.54	C/D
	RTR/HRTR - C - 240 x 150	.240 x .150 / 6.10 x 3.81	.160 x .100 / 4.06 x 2.54	C/D
	RTR/HRTR - C - 260 x 160	.260 x .160 / 6.60 x 4.06	.160 x .100 / 4.06 x 2.54	C/D
	RTR/HRTR - C - 280 x 170	.280 x .170 / 7.11 x 4.32	.160 x .100 / 4.06 x 2.54	C/D
	RTR/HRTR - C - 300 x 180	.300 x .180 / 7.62 x 4.57	.160 x .100 / 4.06 x 2.54	C/D
	RTR/HRTR - C - 300 x 190	.300 x .190 / 7.62 x 4.83	.160 x .100 / 4.06 x 2.54	C/D
Square Face	RTR/HRTR - D - 260 x 260	.260 x .260 / 6.60 x 6.60	.240 x .140 / 6.10 x 3.56	C/D
	RTR/HRTR - D - 280 x 280	.280 x .280 / 7.11 x 7.11	.240 x .140 / 6.10 x 3.56	C/D
	RTR/HRTR - D - 300 x 300	.300 x .300 / 7.62 x 7.62	.240 x .140 / 6.10 x 3.56	C/D
	RTR/HRTR - D - 320 x 320	.320 x .320 / 8.13 x 8.13	.240 x .140 / 6.10 x 3.56	C/D
	RTR/HRTR - D - 340 x 340	.340 x .340 / 8.64 x 8.64	.240 x .140 / 6.10 x 3.56	C/D
	RTR/HRTR - D - 360 x 360	.360 x .360 / 9.14 x 9.14	.240 x .140 / 6.10 x 3.56	C/D
	RTR/HRTR - D - 380 x 380	.380 x .380 / 9.65 x 9.65	.240 x .140 / 6.10 x 3.56	C/D
	RTR/HRTR - D - 400 x 400	.400 x .400 / 10.16 x 10.16	.240 x .140 / 6.10 x 3.56	C/D
Square Face	RTR/HRTR - D - 340 x 260	.340 x .260 / 8.64 x 6.60	.240 x .140 / 6.10 x 3.56	C/D
	RTR/HRTR - D - 360 x 270	.360 x .270 / 9.14 x 6.86	.240 x .140 / 6.10 x 3.56	C/D
	RTR/HRTR - D - 380 x 280	.380 x .280 / 9.65 x 7.11	.240 x .140 / 6.10 x 3.56	C/D
	RTR/HRTR - D - 400 x 300	.400 x .300 / 10.16 x 7.62	.240 x .140 / 6.10 x 3.56	C/D

PICK UP TOOLS

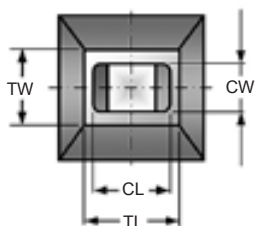

Type C

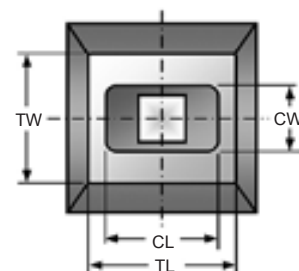

Type D

CTR / HCTR / HCTE TYPE A, B, C & D - CONICAL TIP RUBBER

Tip Type	ØF inch / mm	ØH / CL x CW inch / mm	Shank Insert Type
CTR/HCTR/HCTE - A6 - 012	.012 / 0.30	.006 / 0.15	A/B
CTR/HCTR/HCTE - A5 - 015	.015 / 0.38	.008 / 0.20	A/B
CTR/HCTR/HCTE - A4 - 020	.020 / 0.51	.010 / 0.25	A/B
CTR/HCTR/HCTE - A3 - 025	.025 / 0.63	.015 / 0.38	A/B
CTR/HCTR/HCTE - A3 - 030	.030 / 0.76	.015 / 0.38	A/B
CTR/HCTR/HCTE - A3 - 035	.035 / 0.89	.015 / 0.38	A/B
CTR/HCTR/HCTE - A3 - 040	.040 / 1.02	.015 / 0.38	A/B
CTR/HCTR/HCTE - A2 - 045	.045 / 1.14	.025 / 0.63	A/B
CTR/HCTR/HCTE - A2 - 050	.050 / 1.27	.025 / 0.63	A/B
CTR/HCTR/HCTE - A1 - 060	.060 / 1.52	.035 / 0.89	A/B
CTR/HCTR/HCTE - A1 - 070	.070 / 1.78	.035 / 0.89	A/B
CTR/HCTR/HCTE - A1 - 080	.080 / 2.03	.035 / 0.89	A/B
CTR/HCTR/HCTE - A1 - 090	.090 / 2.29	.035 / 0.89	A/B
CTR/HCTR/HCTE - A1 - 100	.100 / 2.54	.035 / 0.89	A/B
CTR/HCTR/HCTE - A1 - 120	.120 / 3.05	.035 / 0.89	A/B
CTR/HCTR/HCTE - A1 - 130	.130 / 3.30	.035 / 0.89	A/B
<hr/>			
CTR/HCTR/HCTE - B - 140	.140 / 3.56	.100 x .060 / 2.54 x 1.52	A/B
CTR/HCTR/HCTE - B - 160	.160 / 4.06	.100 x .060 / 2.54 x 1.52	A/B
CTR/HCTR/HCTE - B - 180	.180 / 4.57	.100 x .060 / 2.54 x 1.52	A/B
CTR/HCTR/HCTE - B - 200	.200 / 5.08	.100 x .060 / 2.54 x 1.52	A/B
<hr/>			
CTR/HCTR - C - 220	.220 / 5.59	.160 x .100 / 4.06 x 2.54	C/D
CTR/HCTR - C - 240	.240 / 6.10	.160 x .100 / 4.06 x 2.54	C/D
CTR/HCTR - C - 260	.260 / 6.60	.160 x .100 / 4.06 x 2.54	C/D
CTR/HCTR - C - 280	.280 / 7.11	.160 x .100 / 4.06 x 2.54	C/D
CTR/HCTR - C - 300	.300 / 7.62	.160 x .100 / 4.06 x 2.54	C/D
<hr/>			
CTR/HCTR - D - 320	.320 / 8.13	.240 x .140 / 6.10 x 3.56	C/D
CTR/HCTR - D - 340	.340 / 8.64	.240 x .140 / 6.10 x 3.56	C/D
CTR/HCTR - D - 360	.360 / 9.14	.240 x .140 / 6.10 x 3.56	C/D
CTR/HCTR - D - 380	.380 / 9.65	.240 x .140 / 6.10 x 3.56	C/D
CTR/HCTR - D - 400	.400 / 10.16	.240 x .140 / 6.10 x 3.56	C/D

Conical Face



Type A

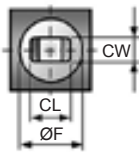

Type B

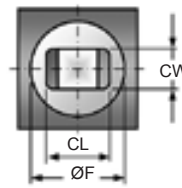

Type C

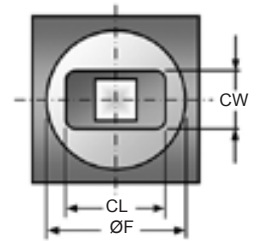

Type D

How To Order

TIP ONLY	Tip Configuration	Insert Type	Dimensions ØF / TLxTW	Remarks
EXAMPLE:	CTR	A1	060	Countersunk WT = 0.25
	HCTR	B	4.57	
	RTR	C	300 x 180	
	HRTE	A3	030 x 045	
SHANK ONLY	Shank Style & Length	Insert Type		
EXAMPLE :	2102- 19	A/B Shank		
	GS	C/D Shank		

RTR-D2-CG:
RTR-D3-CG:
RTR-D3-MH:

RECTANGULAR TIP RUBBER WITH DOUBLE Y CROSS-GROOVE
RECTANGULAR TIP RUBBER WITH CROSS-GROOVE
RECTANGULAR TIP RUBBER WITH MULTI-HOLE



For some applications, like handling large thin die, the preferred vacuum cavity is different than the traditional round or rectangular shape found on common rubber tips. The desired design is rather a cross groove or X sign or a multi hole configuration. This feature prevents the die to warp inside the vacuum cavity and to cause poor wetting or incomplete epoxy coverage during die placement. The outer shape of the tip depends on the size of TL/TW: 2 or 4 tapered walls or vertical walls. Various custom vacuum channel or cavity configurations are possible on request.

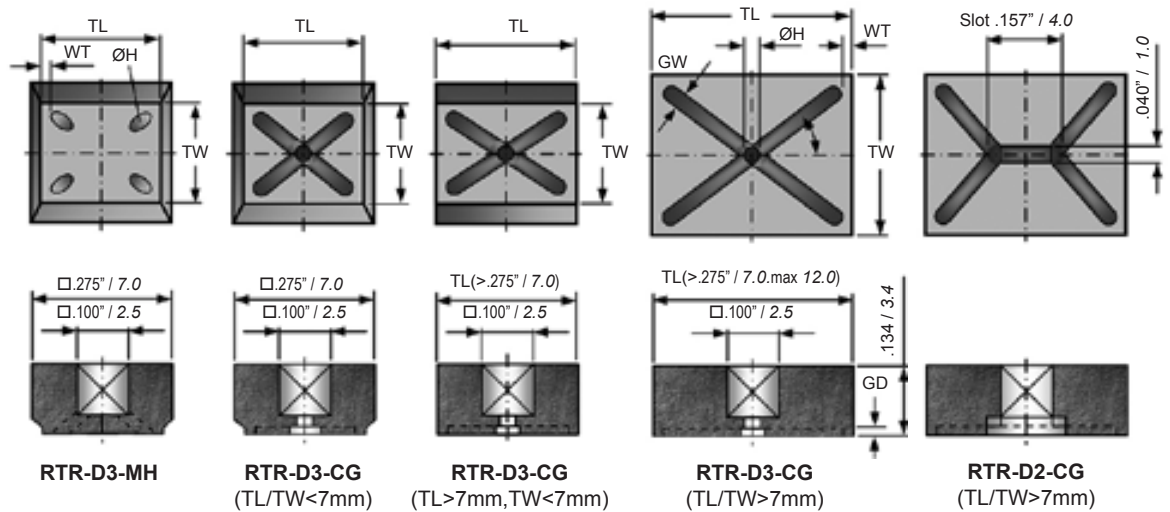

The Maximum TL or TW dimension for RTR-D2-CG, RTR-D3-CG and RTR-D3-MH is .472" / 12 mm. By default, the following value will be used: GW=0.8mm, GD=0.4mm, WT=0.5mm, H=GW, GA=Diag. By default, the quantity of holes for MH tip configuration is 4.

How To Order						
TIP ONLY	EXAMPLE:	Tip Configuration	-	Dimensions TLxTW	-	Options (GW)-(GD)-(WT)-(H)-(GA)
		RTR-D3-CG	-	200 X 160	-	
		RTR-D3-CG	-	300 X 150	-	GW=0.6mm- GD=0.2mm
		RTR-D2-CG	-	400 X 295	-	GW=1.0mm- GD=0.3mm
TIP ONLY	EXAMPLE:	Tip Configuration	-	Dimensions TLxTW	-	Dimensions ØH
		RTR-D3-MH	-	200 X 160	-	1.0mm
		RTR-D3-MH	-	300 X 150	-	0.8mm
						Options (WT)
						1.5mm

PICKUP TOOLS

- PCTR : PURE CONICAL TIP RUBBER**
- FCTR : FLIP-CHIP CONICAL TIP RUBBER**
- BPCT : BLACK PLASTIC CONICAL TIP**

Thermoplastic elastomer combines the properties of thermoplastics and rubbers in one polymer. The very high purity has made 74A the material of choice for many products in the medical and pharmaceutical industry. It is therefore well suited to the increasing demand of higher quality tools for the microelectronic world.



Features

- **Very high purity**
- **Static Dissipative**
- **Small wall size**
- **Flexible design**
- **Leaves no dark mark on die**
- **Molded finished to shape**
- **Very reproducible geometry**
- **Special formulation for Flip Chip**
- **Custom molded tip design**
- **Spring effect for small tip sizes**

Being aware of the need to offer products able to cope with today's large and diverse application, SPT proposes a version of FCTR tips tailored specifically for the requirements of Flip-chip assembly.



PCTR-A-060



BPCT-A-040



FCTR-C-200



Clean Packing

All thermoplastic tips are individually segregated in anti-static boxes and packed under filtered laminar air flow class 100. The tip surface remains protected from friction or contact with neighbors or foreign material. Quantity per box: 20 pieces



Available Molded BPCT/PCTR & FCTR Size

Type BPCT / PCTR	Type FCTR	Face Diameter ØF inch / mm	Wall Thickness WT inch / mm	Shank Insert	
				BPCT / PCTR	FCTR
BPCT/PCTR -A-020	NA	.020 / 0.50	.0050 / 0.13	A/B XS	-
BPCT/PCTR -A-025	NA	.025 / 0.63	.0064 / 0.16	A/B XS	-
BPCT/PCTR -A-030	NA	.030 / 0.76	.0050 / 0.13	A/B	-
BPCT/PCTR -A-035	NA	.035 / 0.90	.0075 / 0.19	A/B	-
BPCT/PCTR -A-040	NA	.040 / 1.02	.0100 / 0.25	A/B	-
BPCT/PCTR -A-045	NA	.045 / 1.14	.0090 / 0.23	A/B	-
BPCT/PCTR -A-050	FCTR-A-050	.050 / 1.27	.0115 / 0.29	A/B	A/B XL
BPCT/PCTR -A-060	FCTR-A-060	.060 / 1.52	.012 / 0.30	A/B	A/B XL
BPCT/PCTR -A-070	FCTR-A-070	.070 / 1.78	.012 / 0.30	A/B	A/B XL
BPCT/PCTR -A-080	FCTR-A-080	.080 / 2.03	.012 / 0.30	A/B	A/B XL
BPCT/PCTR -A-090	FCTR-A-090	.090 / 2.29	.010 / 0.25	A/B	A/B XL
BPCT/PCTR -A-100	FCTR-A-100	.100 / 2.54	.010 / 0.25	A/B	A/B XL
BPCT/PCTR -A-120	FCTR-A-120	.120 / 3.05	.010 / 0.25	A/B	A/B XL
BPCT/PCTR -A-140	FCTR-A-140	.140 / 3.56	.010 / 0.25	A/B	A/B XL
BPCT/PCTR -A-160	FCTR-A-160	.160 / 4.06	.010 / 0.25	A/B	A/B XL
BPCT/PCTR -A-180	FCTR-A-180	.180 / 4.57	.010 / 0.25	A/B	A/B XL
BPCT/PCTR -C-200	FCTR-C-200	.200 / 5.08	.016 / 0.40	C/D	C/D XL
BPCT/PCTR -C-220	FCTR-C-220	.220 / 5.59	.016 / 0.40	C/D	C/D XL
BPCT/PCTR -C-240	FCTR-C-240	.240 / 6.10	.016 / 0.40	C/D	C/D XL
BPCT/PCTR -C-260	FCTR-C-260	.260 / 6.60	.016 / 0.40	C/D	C/D XL
BPCT/PCTR -C-280	FCTR-C-280	.280 / 7.11	.016 / 0.40	C/D	C/D XL
BPCT/PCTR -C-300	FCTR-C-300	.300 / 7.62	.016 / 0.40	C/D	C/D XL
BPCT/PCTR -C-320	FCTR-C-320	.320 / 8.13	.016 / 0.40	C/D	C/D XL
BPCT/PCTR -C-360	FCTR-C-360	.360 / 9.14	.016 / 0.40	C/D	C/D XL
BPCT/PCTR -C-400	FCTR-C-400	.400 / 10.16	.016 / 0.40	C/D	C/D XL

The external PCTR diameter OD and the internal square insert dimensions are distributed in two possible sets: Insert type A & C. A few rectangular tips are also available on request. It is recommended to use SPT shanks with tight tolerances and proper design for high accuracy tip positioning and stability. The shank A/B XS give better support to very small tips. The shank XL is larger for tighter grip on soft material.

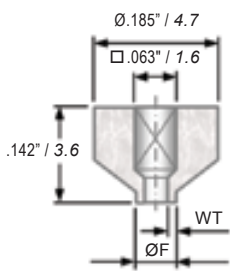

PCTR-A-020 to 080

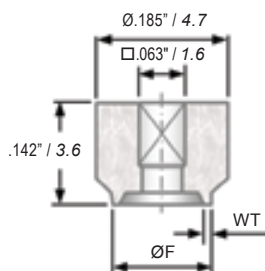

PCTR-A-090 to 180

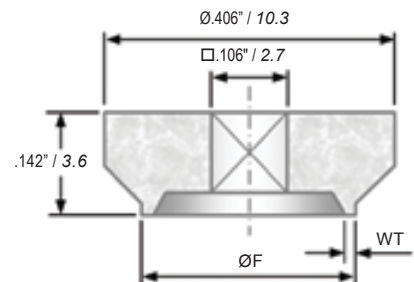

PCTR-C-200 to 400

How To Order				Shank Insert Types					
TIP ONLY	EXAMPLE :	Tip Configuration	-	Insert Type	-	Dimensions ØF	A/B XS	A/B	A/B XL
		PCTR	-	C	-	260			
		FCTR	-	A	-	160			
		BPCT	-	A	-	040			
SHANK ONLY	EXAMPLE :	Shank Style & Length	-	Insert Type			C/D	C/D XL	
		2102 - 19 GS	-	A/B Shank C/D XL Shank					

SC : SUCTION CUP
HSC : HIGH TEMPERATURE SUCTION CUP

The soft lips of the suction cup provide a gentle touch to the die surface while the flexible tip adapts to the substrate planar level. Large contact diameter extends the field of application of these pick-up tools compared to the classical rubber tips.

Two material grades are available: HSC: ESD safe Silicone for high temperature (200°C) utilization and SC: Static Dissipative non marking Nitrile for low temperature (100°C) utilization.

Low Temp Type	High Temp Type	Ø F inch / mm	Ø H inch / mm	Height HT inch / mm	Ø OD inch / mm
SC-125	HSC-125	.125 / 3.18	.035 / 0.89	.180 / 4.57	.100 / 2.54
SC-187	HSC-187	.187 / 4.75	.035 / 0.89	.200 / 5.08	.130 / 3.30
SC-250	HSC-250	.250 / 6.35	.035 / 0.89	.200 / 5.08	.100 / 2.54
SC-375	HSC-375	.375 / 9.53	.035 / 0.89	.250 / 6.35	.125 / 3.18
SC-500	HSC-500	.500 / 12.70	.035 / 0.89	.300 / 7.62	.160 / 4.06
SC-625	HSC-625	.625 / 15.88	.035 / 0.89	.315 / 8.00	.160 / 4.06
SC-750	HSC-750	.750 / 19.05	.035 / 0.89	.320 / 8.13	.160 / 4.06

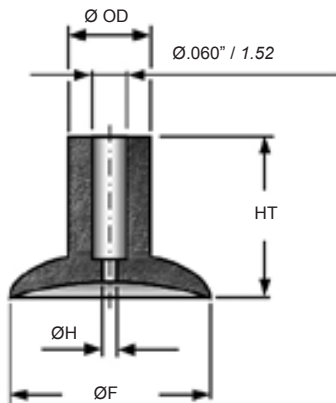

How To Order			
TIP ONLY		Tip Configuration	- Dimensions ØF
	EXAMPLE:	SC	- 125
		HSC	- 250
SHANK ONLY		Shank Style & Length L	- Shank /Insert Configuration
	EXAMPLE :	2102 - 16	- SC Shank
		TSK	- SC Shank

RPCT : REPLACEABLE PLASTIC CONICAL TIP

SPT proposes by default white Delrin® replaceable tips which possess a very low friction coefficient while harder than conventional rubber tips. Delrin is a good material alternative when facing “sticky die” problem. SPT greatly recommends the molded (*) Delrin sizes which are more economical and have a smoother geometry transition than machined tips, thus preventing damage to the die surface. Delrin can be used to temperature up to 135°C.

For smooth and comfortable installation or removal of the RPCT tip on cylindrical stud shank, we recommend to use SPT tight tolerance shank styles.

For other available RPCT plastic materials, consult the list on page 16.

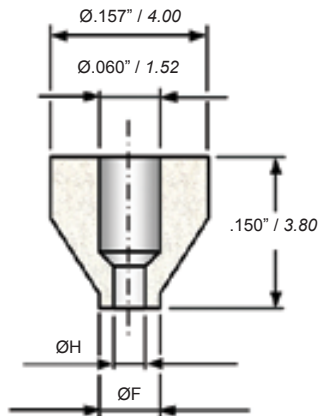

Tip Configuration	Ø F inch / mm	Ø H inch / mm
RPCT-015	.015 / 0.38	.006 / 0.15
RPCT-020	.020 / 0.51	.010 / 0.25
RPCT-025	.025 / 0.63	.012 / 0.30
* RPCT-030	.030 / 0.76	.015 / 0.38
* RPCT-040	.040 / 1.02	.020 / 0.51
* RPCT-050	.050 / 1.27	.025 / 0.64
* RPCT-060	.060 / 1.52	.031 / 0.79
RPCT-070	.070 / 1.78	.035 / 0.89
RPCT-080	.080 / 2.03	.046 / 1.17
RPCT-090	.090 / 2.29	.046 / 1.17
RPCT-100	.100 / 2.50	.050 / 1.27
RPCT-120	.120 / 3.05	.060 / 1.52
RPCT-140	.140 / 3.56	.060 / 1.52

PICK UP TOOLS



How To Order										
TIP ONLY	<p style="text-align: center;">Tip Configuration</p> <p>EXAMPLE: RPCT-050 (By default material is DEL) RPCT-HTV21-060</p>									
SHANK ONLY	<table border="0"> <tr> <td style="text-align: center;">Shank Style & Length L</td> <td style="text-align: center;">-</td> <td style="text-align: center;">Shank /Insert Configuration</td> </tr> <tr> <td>EXAMPLE :</td> <td>2101 - .315</td> <td>- RPCT Shank</td> </tr> <tr> <td></td> <td>1059D</td> <td>- RPCT Shank</td> </tr> </table>	Shank Style & Length L	-	Shank /Insert Configuration	EXAMPLE :	2101 - .315	- RPCT Shank		1059D	- RPCT Shank
Shank Style & Length L	-	Shank /Insert Configuration								
EXAMPLE :	2101 - .315	- RPCT Shank								
	1059D	- RPCT Shank								

ST : REPLACEABLE CYLINDRICAL SILICONE TIP

For application where very soft surface contact is necessary or when there is difficulty to reach acceptable vacuum level, ST tip represents an alternative to other harder rubber materials. The silicone translucent rubber ST has an hardness of 55 ShoreA and excellent long temperature exposure resistance up to 200°C. ST are made out of silicone tubing.

Tip Configuration	Ø F inch / mm	Ø H inch / mm
ST-040	.040 / 1.02	.020 / 0.51
ST-050	.050 / 1.27	.025 / 0.64
ST-060	.060 / 1.52	.030 / 0.76
ST-080	.080 / 2.03	.040 / 1.02
ST-100	.100 / 2.54	.050 / 1.27
ST-120	.120 / 3.05	.060 / 1.52
ST-160	.160 / 4.06	.080 / 2.03
ST-200	.200 / 5.08	.100 / 2.54

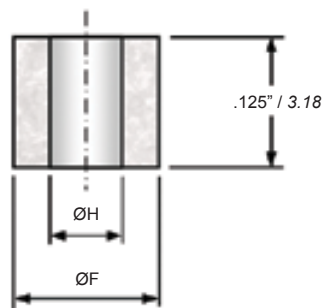

Note :

For each ST size, a different shank, adapted to the corresponding ØH, is necessary. See available shank styles at pages 56-63

How To Order	
TIP ONLY	Tip Configuration EXAMPLE : ST-080
SHANK ONLY	Shank Style & Length L - Shank /Insert Configuration EXAMPLE : 2138 - ST-080 Shank

2151-CT : THREADED REPLACEABLE CONICAL TIP

Aside from our Replaceable Plastic Conical Tip (RPCT), we also offer the common threaded type replaceable tip in 2 piece construction. The tip can also be made from our available range of plastic material (See page 16). The design is adaptable to most shank styles.

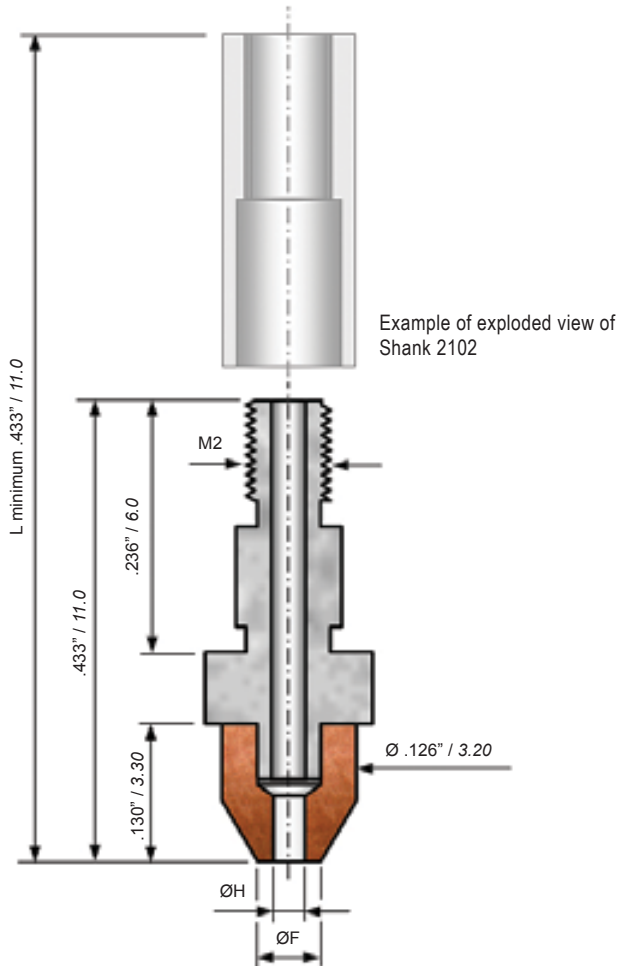

PICK UP TOOLS

How To Order					
TIP ONLY		Tip Configuration	- Mat'l	- Tip Style	- Dimensions ØF - ØH
	EXAMPLE :	2151	- TOR	- CT	.020 - .010
SHANK ONLY		Shank Style & Length L	- Insert Type		
	EXAMPLE :	GS	- 2151 Shank		
		2102 - .550	- 2151 Shank		

CT : CONICAL TIP

These conical Tip Pick-up tools do not have replaceable tips. The body is made in stainless steel or other appropriate metal into which the tip, made of another material, is pressed or glued. For Tungsten Carbide (W) tip or upon request the complete pick-up tool is made out of one single material piece. The main advantage of Conical Tip tools, in regard to replaceable tip, is to allow a better access in application where clearance around the die placement target is limited. Preference against wear resistance is given to W for face diameter below 0.4mm.

$\varnothing F$ inch / mm	$\varnothing H$ inch / mm	WT inch / mm
.008 / 0.20	.004 / 0.10	.0020 / 0.050
.010 / 0.25	.006 / 0.15	.0020 / 0.050
.011 / 0.28	.006 / 0.15	.0025 / 0.065
.012 / 0.30	.006 / 0.15	.0030 / 0.075
.015 / 0.38	.006 / 0.15	.0045 / 0.115
.020 / 0.50	.010 / 0.25	.0050 / 0.125
.025 / 0.63	.010 / 0.25	.0075 / 0.190
.030 / 0.76	.015 / 0.38	.0075 / 0.190
.040 / 1.00	.020 / 0.50	.0100 / 0.250
.060 / 1.52	.030 / 0.76	.0150 / 0.380
.080 / 2.00	.040 / 1.00	.0200 / 0.500



Small Geometry
W Material



Small Geometry
Plastic Material



Large Geometry
Plastic Material

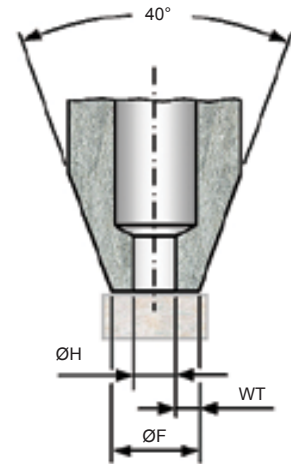
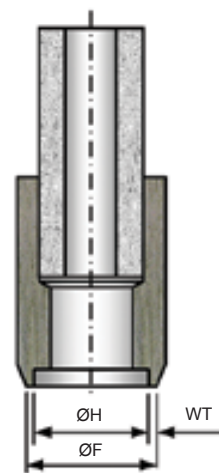

How To Order

	Shank Style & Length	Mat'l	Tip Config.	Dimensions $\varnothing F$ - $\varnothing H$ - WT
EXAMPLE :	2102-.750	- HTV	- CT	- .060 - .030 - .015
	*2102S-.750	- DEL	- CT	- 1.50 - 0.76 - 0.38
	2101-16	- W	- CT	- 1.00 - 0.50 - 0.25
	MC	- TOR	- CT	- 1.50 - 0.80 - 0.35

Note : For Material information and selection see page 16
 For Large Geometry 'W' material we propose RT type of tool
 * 2102S shank and tip is made of a single material
 For plastic material, the smallest Hole diameter is .004" / 0.10mm

RT : RECTANGULAR TIP

The same remarks given for the conical pick-up tools CT are valid for RT type. When the length/width ratio of the die is too large, the preference is given to rectangular tip RT which is less prone to die rotation than CT tool. In fact, the interface between the tool and die will generate more friction when facing displacement forces than interfaces between air and die. Even with square die, the contact area of RT is significantly increased by 27% compared to CT contact area. Diameter H is by default approx. 50% of the smallest of TL, TW.

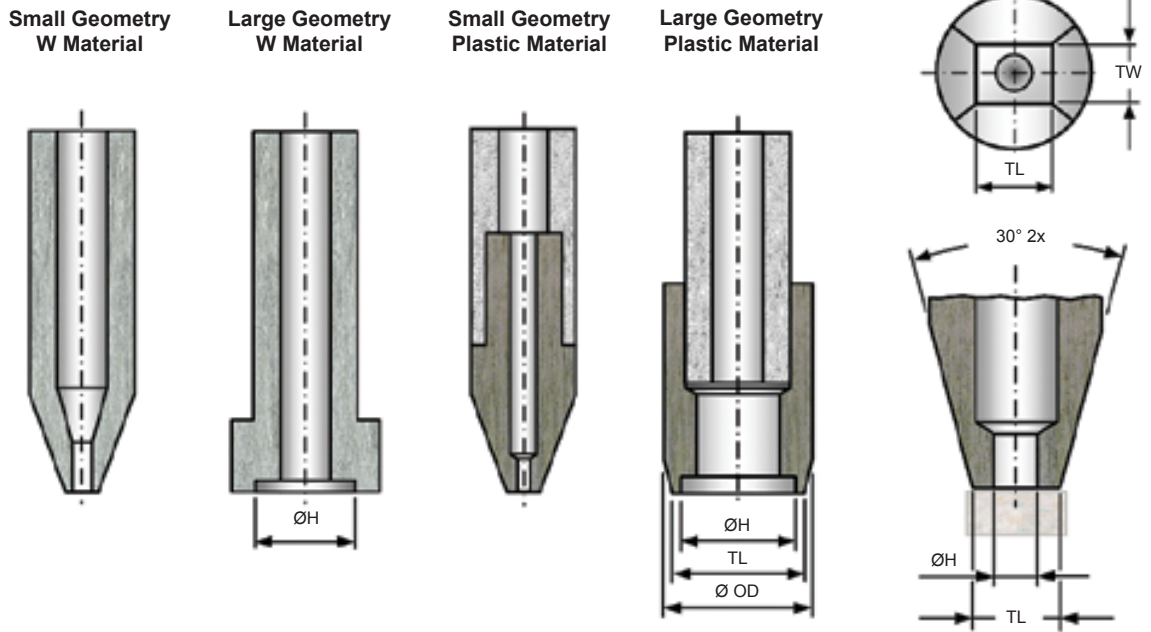

The rather simple geometry of a standard RT tool is frequently adapted to meet more specific requirements. Ultra-thin die or MEMS containing delicate structures, like membranes or air gaps, must be handled with more sophisticated tools. Multi-holes or porous tip material, together with diverse vacuum distribution designs, belong to this tool category.

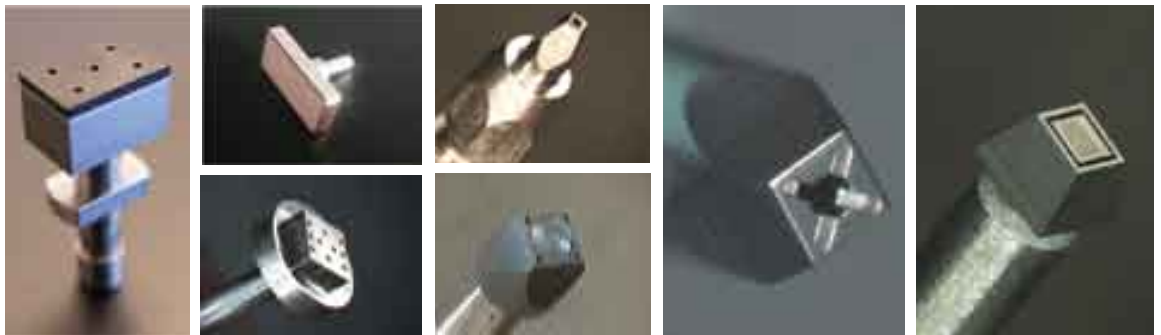

How To Order

	Shank Style & Length	Mat'l	Tip Config.	Dimensions TL - TW - (ØH)
EXAMPLE :	2102-.750	- HTV	- RT	- .080 - .020
	MC	- TOR	- RT	- 1.50 - 0.80 - H= 0.40
	2138	- P13	- RT	- 4.00 - 3.75 (porous plastic)
	2141	- NBR	- RT	- 16.00 - 9.00 - 5 x H=1.0.

PL : PERIPHERAL PICK-UP TOOL

PL tool offers the flexibility to select custom tool outer dimension, wall size and vacuum hole dimension. Peripheral pick-up are particularly suited in the following situations :

- When the surface contact area between the tool and the die must be minimized.
- When certain die areas are to be protected from tool contact.
- When vacuum force must be increased (compared to CT or RT pick-up).

PL tools are traditionally proposed in Tungsten Carbide (W) because of the need of very fine wall sizes which are highly polished to eliminate sharp edges preventing damage to the die surface. Softer materials like plastic & rubber are available. See below the compatibility table.

The value wall thickness WT is usually the same around the four edges. Cavity length CL is the length of the die area to be protected from tool contact. Not necessarily the longest dimension but the size of the cavity facing the shank as drawn in the shank list. Cavity width CW is the width of the protected die area.

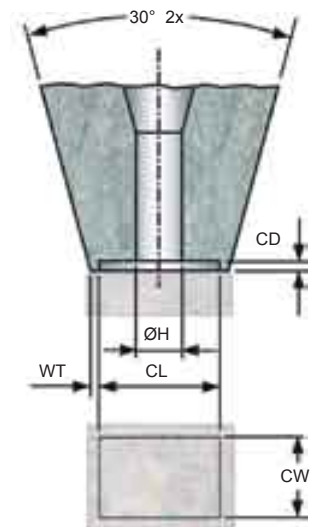
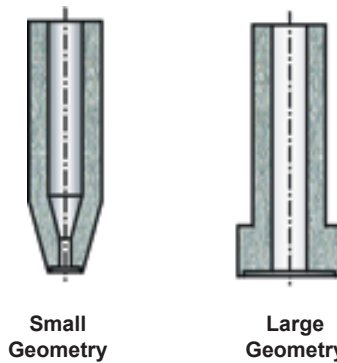

Minimum Dimensions			
Material	CL & CW	WT	CD (default)
W	.005" / 0.130	.001" / 0.025	.003" / 0.076
TOR, HTV, HTV21	.012" / 0.30	.005" / 0.13	.005" / 0.13
DEL	.012" / 0.30	.010" / 0.25	.005" / 0.13
NBR, FKM	.020" / 0.50	.010" / 0.25	.012" / 0.30



How To Order				
	Shank Style & Length	Mat'l	Tip Config.	Dimensions CL - CW - WT - (CD)
EXAMPLE:	MC26	- W	- PL	- .050 - .040 - .003
	2138	- TOR	- PL	- 4.50 - 2.80 - 0.20 - 0.35
	2102-19	- NBR	- PL	- 15.0 - 13.5 - 1.0 - 0.30

DIE COLLET PICK-UP TOOLS

The “Die Collet” has become the symbol of the die attach tools. Despite the fantastic development and integration capacity of a semiconductor die, this tool remains consistent to its very early conception and design. The inverted polished pyramidal walls gently hold the die on four or two edges. The die corners are usually preserved from any contact by the selection of the appropriate die collet type.

Die collet advantages

- Maximum available vacuum surface
- No physical contact with sensitive top die surface.
- Allow pickup with obstructed die surface topology.
- Die auto alignment effect at pickup.
- Good placement accuracy.
- Allow die scrubbing action.
- Well adapted to very small die dimensions.
- Maintenance free and long life tungsten carbide material.



4 Sided Inverted Pyramid Die Collet

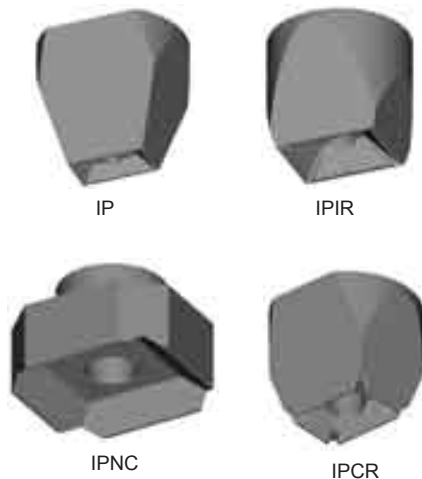

2 Sided Inverted Channel Die Collet



Beside those standard collet types, SPT is manufacturing many other complex tools which are a combination of the above types or tools containing supplementary features required for a specific application. A few examples are illustrated hereafter.

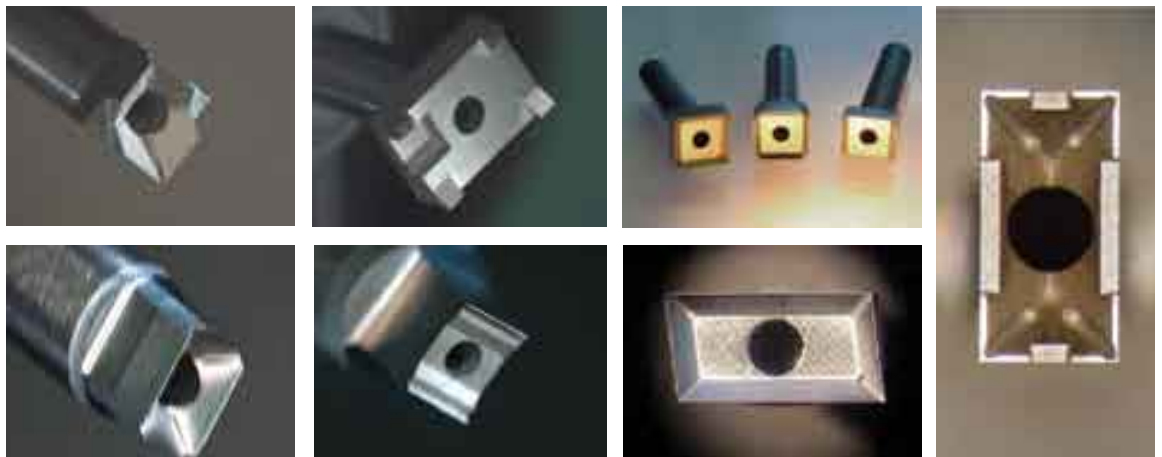

4 SIDED INVERTED PYRAMID DIE COLLET CONFIGURATION SELECTION

For each die size SPT recommends a specific die collet configuration. However, those guidelines are very flexible and usually different configurations can successfully comply to the requirement of most common applications.

IP	IPIR	IPNC	IPCR
Inverted Pyramid	Inverted Pyramid Inner Relief Corner	Inverted Pyramid Notched Corner Relief	Inverted Pyramid Corner Relief
Die width < .020" / 0.50mm	Die width > .020" / 0.50mm to .100" / 2.54mm	Die width > .100" / 2.54mm	Die width > .035" / 0.90mm

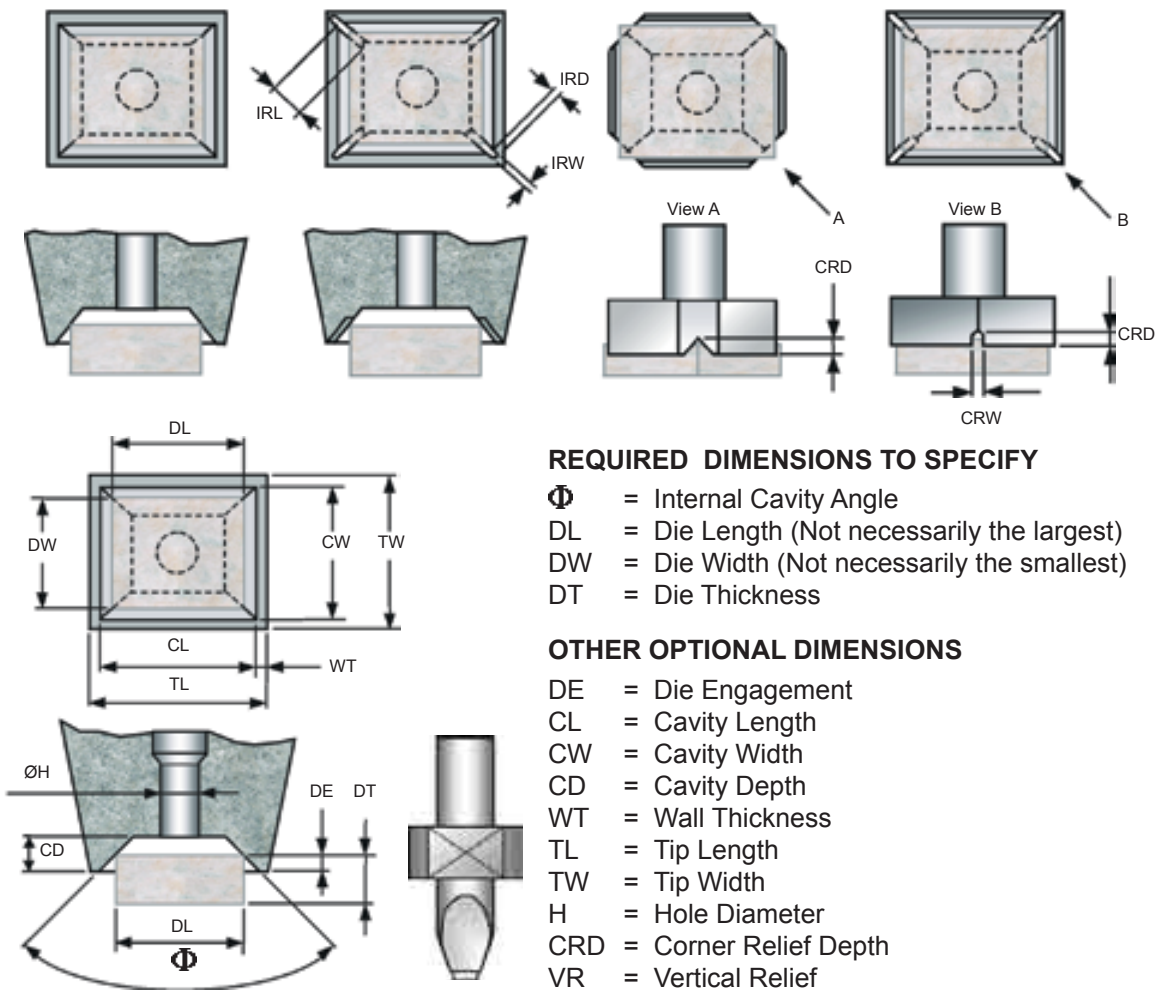

How To Order

	Shank Style & Length	Mat'l	Tip Config.	Dimensions DL - DW - DT - (DE)-(Options)
EXAMPLE:	2143	- W	- IPNC120	- .120 - .110 - .020 - .010
	2101-16	- W	- IPIR90	- 2.54 - 2.28 - 0.50 WT=0.120

DL is the die size when the shank is oriented as drawn in the shank page. Important for non-symmetric shanks

2 SIDED INVERTED PYRAMID DIE COLLET CONFIGURATION CH

This collet configuration is useful where tool access is limited. The die is retained against only two collet side walls. In the other direction, the collet tip (CW) is shorter than the die width (DW).



REQUIRED DIMENSIONS TO SPECIFY

- Φ = Internal Cavity Angle
- DL = Die Length (Not necessarily the largest)
- DW = Die Width (Not necessarily the smallest)
- DT = Die Thickness

OTHER OPTIONAL DIMENSIONS

- DE = Die Engagement
- CL = Cavity Length
- CW = Cavity Width
- CD = Cavity Depth
- WT = Wall Thickness
- TL = Tip Length (Not necessarily the largest)
- TW = Tip Width (= CW) by default $0.9 * DW$
- H = Hole Diameter
- VR = Vertical Relief

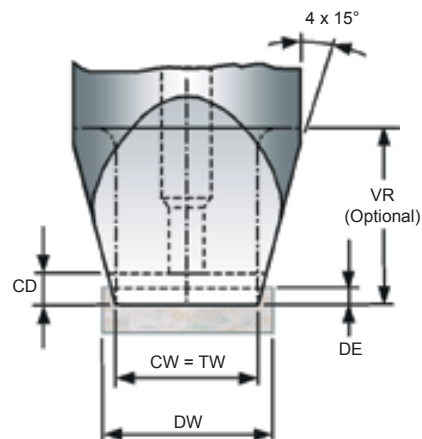
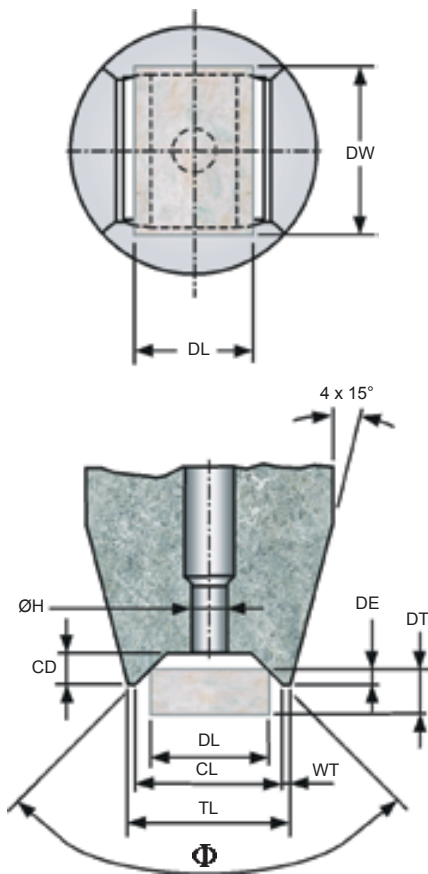

For CH collet, DL is always facing the channel cavity (open side). Usually the shorter die side but may be also the longer side.

For CH collet, DW is always facing the channel wall and correspond usually (but not necessarily) to the longer die side.

How To Order

	Shank Style & Length	Mat'l	Tip Config.	Dimensions DL - DW - DT - (DE)-(Options)
EXAMPLE:	2143	- W	- CH120	- .090 - .100 - .020 - .010
	2101-14	- W	- CH90	- 2.28 - 2.54 - 0.50

RECOMMENDATIONS, GUIDELINES AND STANDARD VALUES

Any non specified dimensions will be selected according to the following rules.

Φ = Internal Standard Cavity Angle :

90° When the shortest of die Length (DL) and Width (DW) is equal or smaller than $.080'' / 2.00mm$

110° When the shortest of die Length (DL) and Width (DW) is greater than $.080'' / 2.00mm$

120° Recommended for 2 sided Channel **CH** collet.

DL = The die length is the dimension (DL) as seen on the die collet drawing on pages 56-63.

The same view is used to represent the shank style. When the selected shank style is not symmetric, the dimension DL must be carefully defined to avoid orientation mistake. Therefore, DL is not necessarily the larger dimension but corresponds to the size of the die when looking at the die collet with the shank position as drawn on page 56-63. For 2 sided Channel **CH** collet only DL is always the die size when facing the collet channel opening.

DW = The die width DW is not necessarily the smaller die dimension. See explanation here above.

For 2 sided Channel **CH** collet only DW is the die size when facing the collet channel wall.

DE = Die Engagement is the amount of die thickness that fits into the cavity.

DE = $\frac{1}{2}$ DT (Die Thickness) when DT is $.010'' / 0.250mm$ or less

DE = $.005'' / 0.130mm$ when DT is greater than $.010'' / 0.250mm$

CL = Opening of the cavity which value depends on DL, DE and Φ :

For $\Phi = 90^\circ$, CL = DL + 2 x DE

For $\Phi = 110^\circ$, CL = DL + 2.86 x DE

For $\Phi = 120^\circ$, CL = DL + 3.46 x DE

In general, CL = DL + (2 x Tan ($\Phi/2$) x DE)

CW = Opening of the cavity which value depends on DW, DE and Φ :

For $\Phi = 90^\circ$, CW = DW + 2 x DE

For $\Phi = 110^\circ$, CW = DW + 2.86 x DE

For $\Phi = 120^\circ$, CW = DW + 3.46 x DE

In general, CW = DW + (2 x Tan ($\Phi/2$) x DE)

For 2 sided Channel **CH** collet only CW = 0.9 x DW

CD = Cavity Depth for CH type only CD = 2 x DE, for other collets $.020'' / 0.51mm$

WT = Wall Thickness.

For smallest size of DL/DW up to $.118'' / 3.00mm$ WT = $.0016'' / 0.040mm$

For smallest size of DL/DW up to $.393'' / 9.99mm$ WT = $.0020'' / 0.050mm$

For smallest size of DL/DW > $.393'' / 9.99mm$ WT = $.0031'' / 0.080mm$

The minimum gap between each die on the plastic foil must be larger than

$WT + (CL-DL)/2 + [Tan (15^\circ) x DE]$ for small geometry collet type and

$WT + (CL-DL)/2$ for large geometry or vertical relief collet, to avoid touching adjacent dice with die collet body during pick-up.

TL = Tip Length = CL + (2 x WT)

TW = Tip Width = CW + (2 x WT)

For 2 sided Channel **CH**, TW = CW

VR = Vertical Relief can improve access where clearance around the die collet is limited

For small geometry die collet VR is typically $.040'' / 1.00mm$

H = The Hole diameter will be typically between 50% to 85% of the smallest DL/DW

When H is smaller than $.025'' / 0.64mm$, a back hole vacuum relief hole of

$.025'' / 0.64mm$ to $.059'' / 1.50mm$ is used depending on the selected shank.

IRD = Inner Relief Distance (into WT) , when WT $\geq .0016'' / 0.040mm$, IRD = (0.5 to 0.75) x WT

When WT < $.0016'' / 0.040mm$, then IRD breakouts through WT (IRD = 1.44 x WT)

IRL = Inner Relief Length, is around 75% of distance from corner of cavity to edge of hole for collet with no Cavity Base. IRL to touch the cavity base for collets with cavity base.

IRW = Inner Relief Width = $.0025'' / 0.064mm$ to $.012'' / 0.305mm$ depending upon die size.

CRD = Corner Relief Depth = DE + $.003'' / 0.076mm$

COMPLIANT TOOLS

The parallelism of the Pick-up tool tips depends on the accuracy of the bonding head set-up and tool face perpendicularity. In many applications, in particular for the opto-electronics, the die placement needs to perfectly match the substrate level. One solution is to allow the tool tip to move freely in respect to the tool body or bonding head axis. The assembly of such tool is made by combining the rigid shank and the tip configuration with a flexible interposer material. Many different designs have been produced by SPT and tested in the field.



The tip configuration and material is not limited. Some of the available flexible materials can also withstand high temperature environment. Another popular application is the placement of bumped die from the back side. The compliance is here necessary to assure a good and uniform contact of the bumps or solder balls with the pad or substrate.



SPRING LOADED TOOLS

In order to prevent any damageable impact of a tool with the die surface during pick-up operation, the tool may have a spring mounted within the shank. The construction may be different based on the required tip material and geometry. Anti-rotation systems are offered as well as spring loaded shank for replaceable plastic or rubber tips.

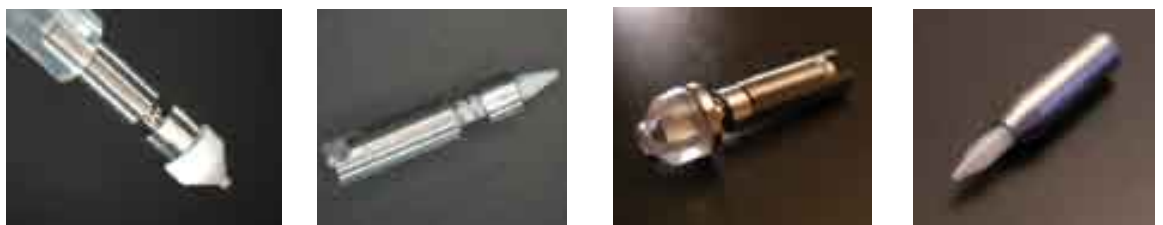

Contact your nearest SPT office if you are interested in any of these specific solutions.

In general, dispensing can be defined as transfer of fluid from a container (typically in syringe) to a substrate in a form of pattern or calculated volumes to host a die or component. In electronics industry, there are various methods that evolved to keep up with the rapid development of manufacturing need for adhesives and conductive epoxies in a wide array of packaging assemblies. Over the years, dispensing application has expanded to other areas needed for new types of packaging encapsulation techniques. A wide variety of fluid materials with different viscosity are being used, from solder paste, conductive adhesives and damming compound to fluxes, thermal paste and underfills.



DISPENSING PROCESS AND TECHNOLOGY

Stamping:

Sometimes known as daubing or pin transfer, this method involves dipping a compliant tool into a reservoir of liquid material then transferring the adhering liquid onto a substrate. This method is frequently used to attain very small dots. However, the process is considered slow as compared to other methods especially if the application requires multiple dots dispensing. To increase throughput, gang (multiple) stamping tool can be employed to stamp an array of dots simultaneously. Grid type stamping tool is also available to print a large area.

Stencil Printing:

Stencil printing is the fastest and most efficient way of applying adhesive to a large area in mass production runs. In this method, a patterned stencil is placed over the substrate and a squeegee force the material through the stencil apertures onto the substrate. This may become complicated when the stencil apertures become so small that the material can no longer print effectively.

Jet-dispensing:

Non-contact jet-dispensing is one of the newer methods in dispensing technologies. Shots of fluid are fired onto the substrate in a non-contact process. Since dispensing dots are typically restricted to one specific size during a run, larger volumes are achieved by accumulating multiple dots. By moving the jet head during deposition, required patterns can be formed.

Nozzle or Needle Dispensing:

In this method, time and air pressure is commonly used to push the fluid through a needle or nozzle to form single dot or multiple dot patterns over the substrate. Over the years, various dispensing platforms with programmable pumps and valves, such as auger and piston have been developed to achieve unique patterns or volumes using single needle or special tapered nozzle. These platforms could either be stand-alone dispensing equipment or integrated on those new pick and place machines.

DISPENSING AND STAMPING TOOLS

We distinguish three different techniques depending on the required dispensing accuracy and the equipment capability.

1. STATIC DISPENSE through single/multi holes or needles.

Tools used in conjunction with appropriate equipment controlling the air/nitrogen dispensing pressure and time

- **EDT**, Epoxy Dispensing Tools



2. PROGRAMMABLE DISPENSE through single tapered tip nozzle.

In most programmable dispensing pumps, typical nozzle designs have been optimized to dispense consistent pattern and volume. Most of these standard nozzles have a distinct chamfered feature that reduces surface tension between the needle and material at the point of separation, therefore less probable to tailing or bridging.

- **CDN**, Common Dispensing Nozzle
- **MDN**, Micro Dispensing Nozzle
- **LDN**, Luer Dispensing Nozzle
- **EDN**, Epoxy Dispensing Nozzle

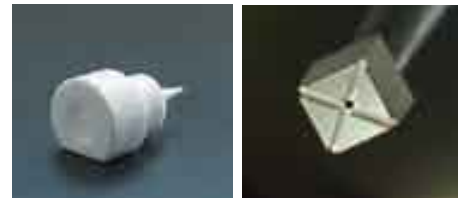

3. STAMPING or Pin Transfer Dispense.

- **REST**, Rubber Epoxy Stamping Tool
- **SEST**, Steel Epoxy Stamping Tool
- **WEST**, Tungsten Epoxy Stamping Tool



Our Epoxy Dispensing Tools (EDT), for die attach applications, are available in many designs to cater to your dispensing needs. EDT's are used in conjunction with appropriate equipment controlling the air/nitrogen dispensing pressure and time.

Consistent coverage and void free adhesion are the main criteria to be satisfied. In order to achieve these, precise fabrication and optimized tool design must be properly carried out.

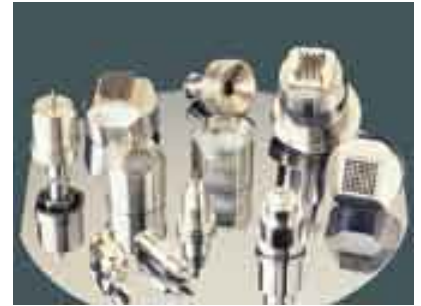

Standard designs

For the range of die size from .008" / 0.20mm to .150" / 3.80mm we recommend groove and single needle/hole type of tool.

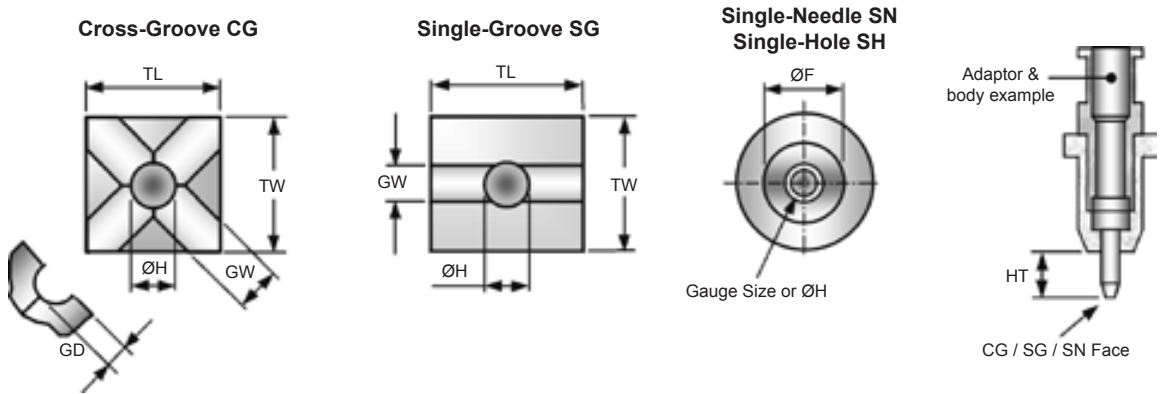

Default Nozzle or needle height HT is .100" / 2.50mm. Specify if otherwise required.

For die size from .100" / 2.50mm and above, the multi-needle (MN) or multi-hole (MH) have found wide acceptance in situations where perfect epoxy coverage is required. Any custom hole/needle layout possible if based on available hole or needle dimensions.

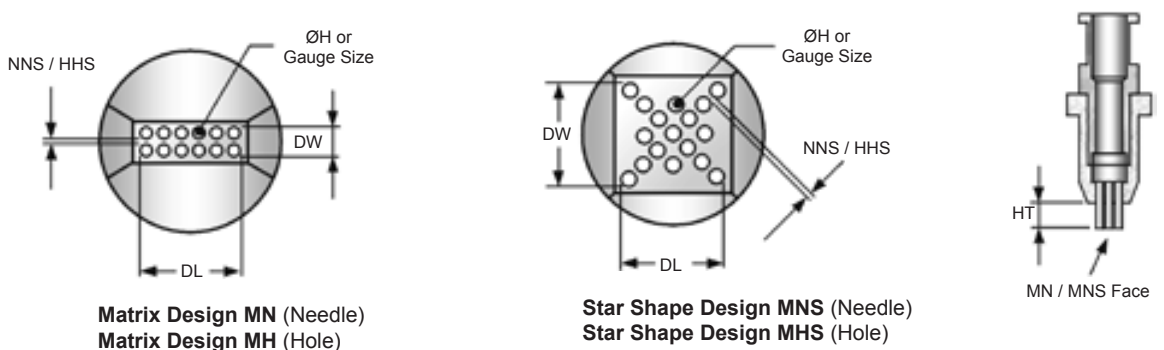

- For die above .120" / 3.00mm
- In line pattern for lengthy shape rectangular die

- For dies greater than .200" / 5.00mm
- Controls epoxy build-up and coverage
- Less voids due to optimized spacing

STANDARD ADAPTOR HEADS (EDT-AH) AND BODY STYLES (EDT-MXX)

<p>MO1 (NEC)</p> <p>(DD max = .275" / 7.0)</p>	<p>MO2 (ASM)</p> <p>(DD max = .334" / 8.5)</p>	<p>MO6 (ESEC)</p> <p>(DD max = .512" / 13.0)</p>	<p>MO8</p> <p>(DD max = .157" / 4.0)</p>
<p>M13</p> <p>(DD max = .157" / 4.0)</p>	<p>M15 (Alphasem)</p> <p>(DD max = .433" / 11.0)</p>	<p>M15A (Alphasem)</p> <p>(DD max = .079" / 2.0)</p>	<p>M0S17 (Universal / ETuan)</p> <p>(DD max = .177" / 4.5)</p>
<p>M18A (B to F) (Shinkawa)</p> <p>(DD max = 10, 14, 14, 18, 22, 16mm)</p>	<p>M20 (NEC)</p> <p>(DD max = 453" / 11.5)</p>	<p>M22 (ASM)</p> <p>(DD max = .315" / 8.0)</p>	<p>M0S26 (ASM AD809)</p> <p>(DD max = not limited)</p>
<p>M30 (ASM)</p>	<p>M32 (ESEC2008)</p> <p>(DD max = not limited)</p>	<p>M40A (ASM AD828/898)</p>	<p>M0S41A (Abacus / Fairchild)</p>

Note: DD is the Die Diagonal and corresponds to the maximum size compatible with a specific body type. For larger die, please consult technical support personnel at our nearest office for a suitable type.

DISPENSING & STAMPING TOOLS

EDT STANDARD NEEDLE DIMENSIONS		
Gauge Size	Outer Ø inch / mm	Inner Ø inch / mm
G12	.109 / 2.77	.085 / 2.16
G13	.095 / 2.41	.071 / 1.80
G14	.083 / 2.11	.063 / 1.60
G15	.072 / 1.83	.054 / 1.37
G16	.065 / 1.65	.047 / 1.19
G17	.058 / 1.47	.042 / 1.07
G18	.049 / 1.24	.033 / 0.83
G19	.042 / 1.07	.027 / 0.68
G20	.035 / 0.89	.023 / 0.58
G21	.032 / 0.81	.020 / 0.51
G22	.028 / 0.71	.016 / 0.40
G23	.025 / 0.64	.013 / 0.33
G24	.022 / 0.56	.012 / 0.30
G25	.020 / 0.51	.010 / 0.25
G26	.018 / 0.46	.010 / 0.25
G27	.016 / 0.41	.008 / 0.20
G28	.014 / 0.36	.007 / 0.18
G30	.012 / 0.30	.006 / 0.15

EDT STANDARD HOLES	
Multi Hole Ø inch / mm	Single Hole Ø inch / mm
.049 / 1.24	min. size
.042 / 1.07	.008 / 0.20
.035 / 0.89	
.032 / 0.81	
.028 / 0.71	
.025 / 0.64	

MINIMUM SPACING
Needle Ø to Needle Ø (NNS) .005 / 0.13
Hole Ø to Hole Ø (HHS) .004 / 0.10

AVAILABLE MATERIAL
SS , Brass : MN, MH, MHS, MNS
W : CG, SG, Hole Ø < .014 / 0.35

How To Order : EDT BODY AND TIP

Cross Groove		Tool Style	Tip Style	Body Style	Mat'l	Dimensions		
						TL x TW	GD	GW - ØH
Single Groove		EXAMPLE :	EDT	CG	M01	W	1.2 x 1.0	0.127 - 0.254 - 0.254
			EDT	SG	M04D	W	.047 x .040	.005 - .010 - .010

Single Hole Single Needle		Tool Style	Tip Style	Body Style	Mat'l	ØF DL x DW	Hole ØH Gauge size	# Holes/ Needles
		EDT	SN	M06	SS	.050 x .040	G20	--

Multi Hole / Needle Matrix		EXAMPLE :	Tool Style	Tip Style	Body Style	Mat'l	DL x DW	Hole ØH Gauge size	# Holes/ Needles
		EDT	MN	M02	SS	.462 x .167	G18	8 x 3	

Multi Hole / Needle Star		EXAMPLE :	Tool Style	Tip Style	Body Style	Mat'l	DL x DW	Hole ØH Gauge size	# Holes/ Needles
		EDT	MNS	M04	SS	8.0 x 8.0	G21	20	

How To Order : EDT Adaptor Head

Adaptor Head		EXAMPLE :	Tool Style	Tip Style	Body Style

For custom design or when you need assistance to choose best design, please fill-out the specification form on page 64

Adaptor Heads come with 2 types of Luer locks that can be fitted into common epoxy barrel or syringe Luer locks :

- Standard Flat Luer (no need to specify)
- Double Lead Thread "DLT" Luer (Specify "DLT" after part number)

CDN : COMMON DISPENSING NOZZLE

In most programmable dispensing pumps, typical nozzle designs have been optimized to dispense consistent pattern and volume. Most of these standard nozzles have a distinct chamfered feature that reduces surface tension between the needle and material at the point of separation, therefore less probable to tailing or bridging. Stand-off pin (SOP**) option is available to control the allowable distance between the needle tip and substrate.

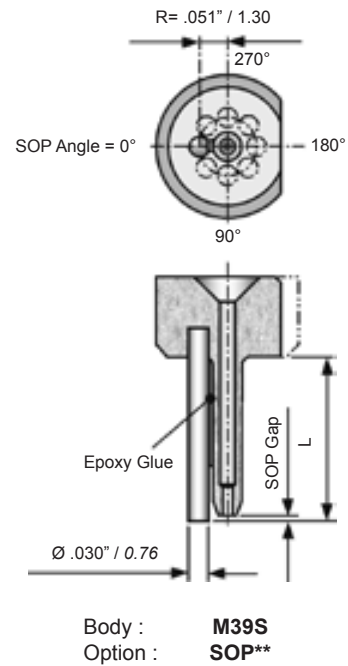
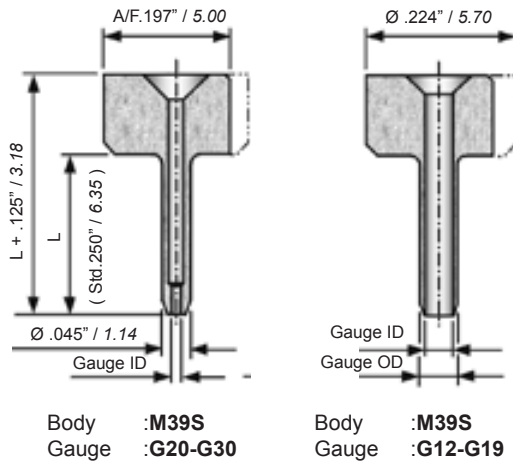
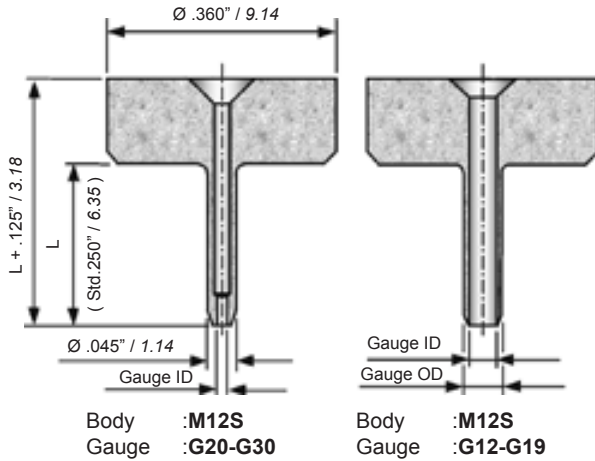

DISPENSING & STAMPING TOOLS

How To Order						
Tool Style	Body	Needle Length L	Mat'l	Needle Gauge*	Option SOP**	Angle - Gap
EXAMPLE: CDN	- M12S	- 6.35mm	- SS	- G23		
CDN	- M39S	- .250"	- SS	- G17		
CDN	- M39S	- .250"	- SS	- G17	- SOP	- 0 DG - .002"

Note : * For Gauge Size information and selection see page 42
 ** Not applicable for gauge sizes 12-16

MDN : MICRO DISPENSING NOZZLE

In the realm of micro-dispensing application, the challenge takes place on methods to achieve small volumes or dots of 200 microns (8mils) and below with high repeatability. Among the methods that have been developed, the ideal approach at present would still be dispensing nozzle using auger screw or piston pumps. As for the nozzle, micro-dispensing requires small orifice with tight tolerance. Smooth internal finishing is also an important factor to enhanced fluid flow.

Small Precision Tools (SPT) positioned itself in meeting the challenge by introducing ceramic dispensing nozzles. Utilizing the ceramic injection molding technology, the nozzles are fully molded as opposed to inserted rolled tubing and stainless steel machining. Different bodies and outer tip configurations are available.



Courtesy of Datacon

The following are the advantages:

- Micro-dots dispensing: Beyond machined stainless steel needle capability.
- Higher MTBA: Internal taper design with slicker finishing for less frequent clogging.

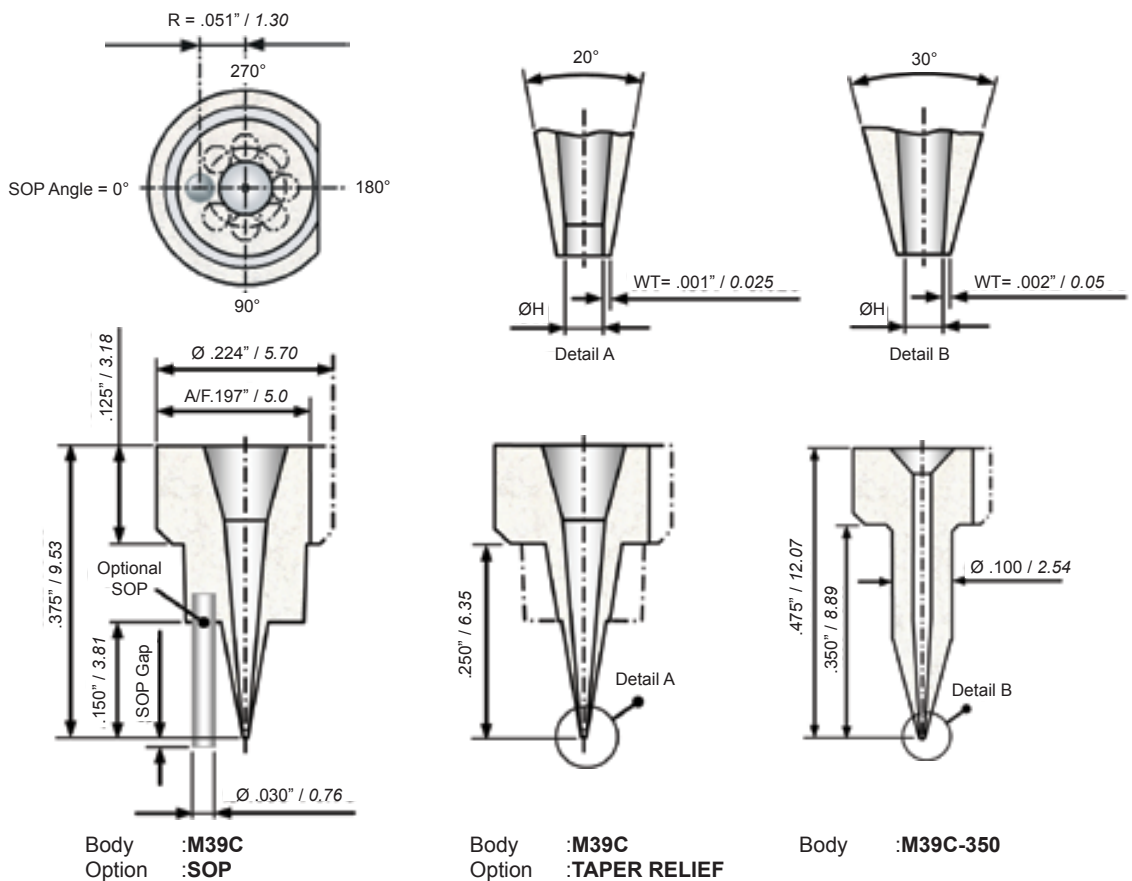

ADAPTOR: LDN & CDN ADAPTOR FOR MICRO DISPENSING NOZZLE

The Micro Dispenser can be advantageously used together with a Luer or CDN Adaptor for those dispensing equipments that use corresponding attachment. The housing nut secures the ceramic MDN tool against the adaptor while keeping proper orientation of the stand-off pin (SOP) option. The Luer Adaptor is composed of a thread and a housing can also host a CDN-M39S metal nozzle.

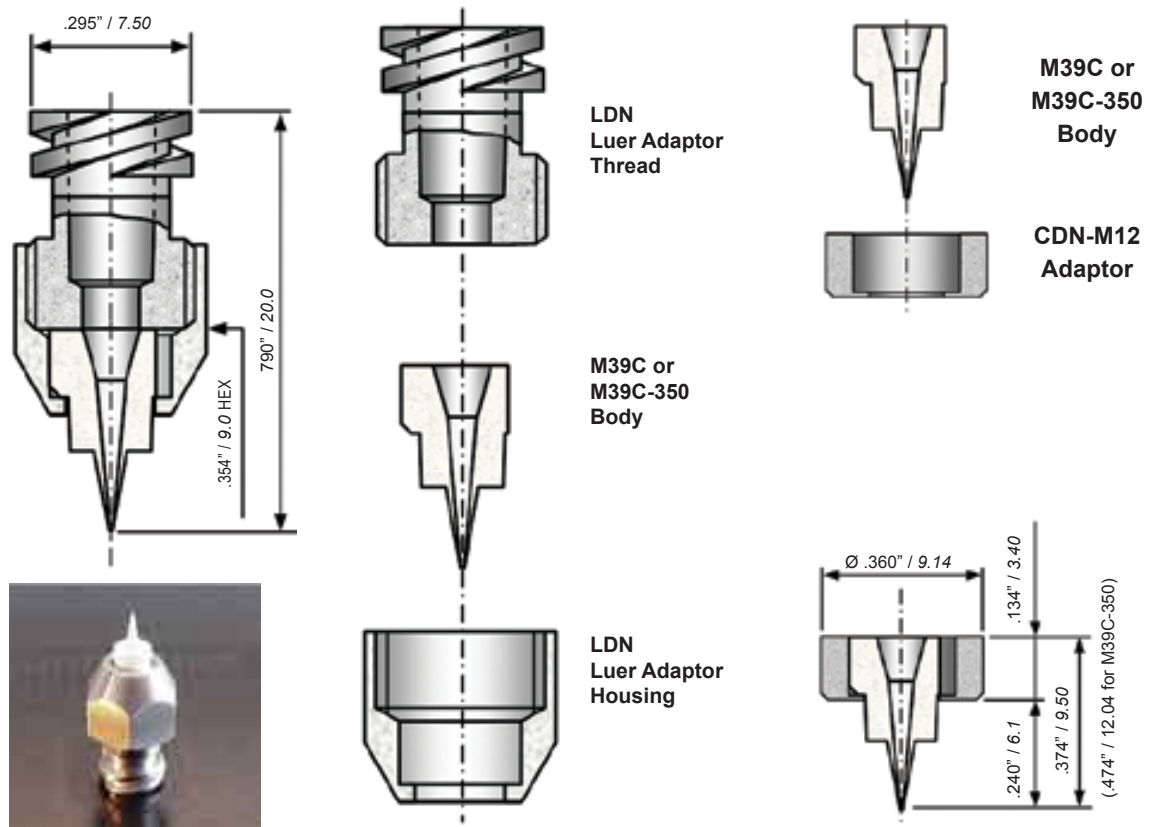

How To Order : LDN & M12 Adaptor

	Tool Style	-	Body	-	Item
EXAMPLE :	LDN	-	M39C	-	Luer Adaptor
	CDN	-	M12	-	Adaptor For M39

Available Hole Size

Inner Ø H inch / mm	Gauge Size Equivalent
.010 / 0.25	G25
.008 / 0.20	G27
.007 / 0.18	G28
.006 / 0.15	G30
.005 / 0.13	G31
.004 / 0.10	G32
.003 / 0.08	G33
.002 / 0.05	G34

How To Order : MDN

	Tool Style	-	Body	-	Mat'l	-	Ø H	Option (SOP- Angle-Gap)
EXAMPLE :	MDN	-	M39C	-	C	-	.008"	
	MDN	-	M39C	-	C	-	.005"	
	MDN	-	M39C	-	C	-	.004"	SOP - 180DG - .002"
	MDN	-	M39C	-	C	-	.007"	With Taper Relief
	MDN	-	M39C-350	-	C	-	G27	

LDN : LUER DISPENSING NOZZLE

Stainless steel tubing with tapered tip inserted into standard Luer type body with full double lead thread, 2-piece construction. Fixed overall length design with variable needle length. Tungsten carbide tip with cross groove option is available for cross print pattern dispensing. This is to minimize epoxy-squeeze out for small die while maintaining complete coverage.

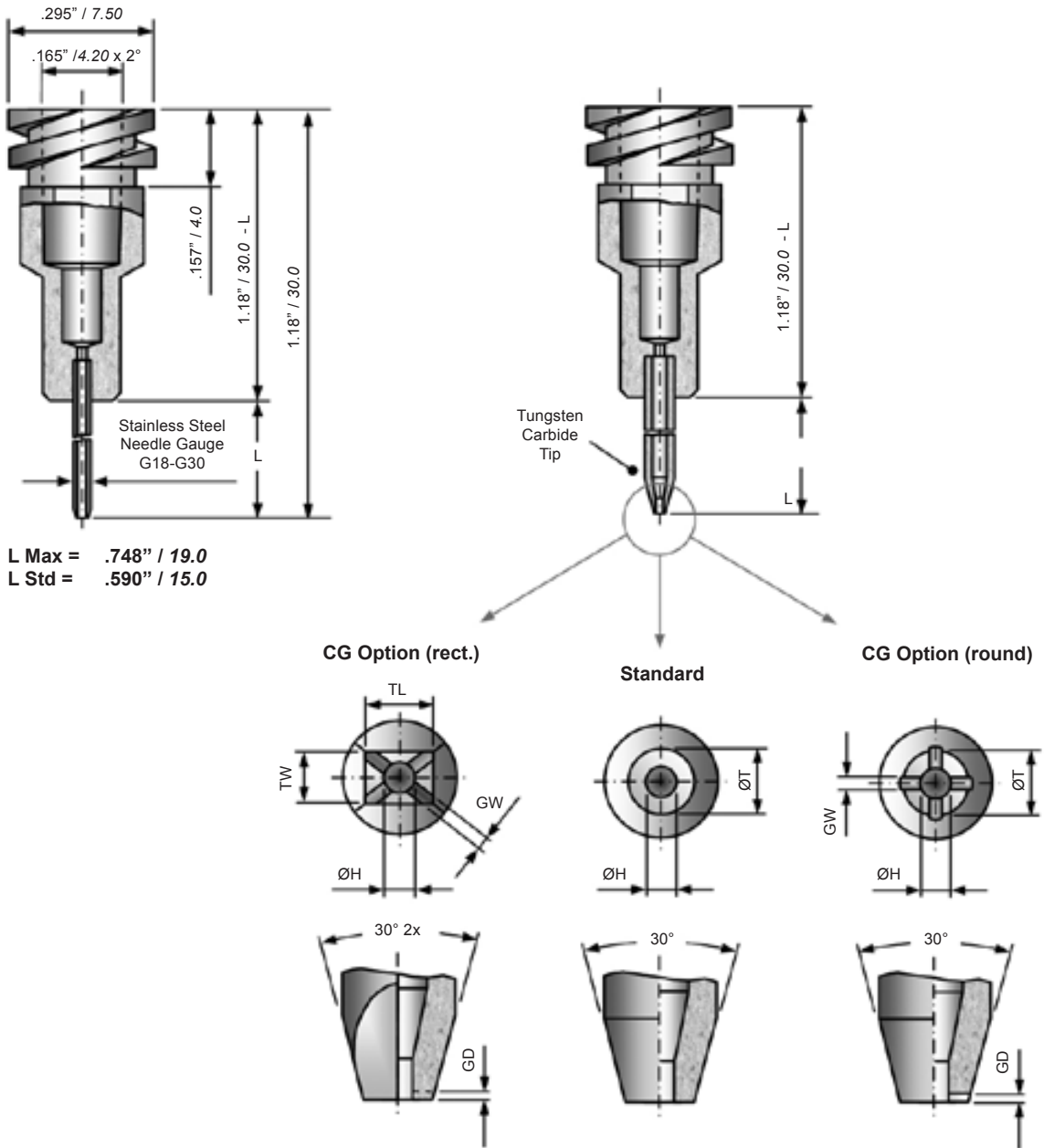

L Max = .748" / 19.0
L Std = .590" / 15.0

How To Order

	Tool Style	-	Needle	-	Tip	-	Ø T	-	GD	-	GW
	Type - Body - L - Mat'l		Gauge* / ØH		Option		TL x TW				
EXAMPLE:	LDN - M40 - .590 - SS	-	G23								
	LDN - M40 - .748 - SS	-	G19								
	LDN - M40 - .590 - W	-	.016	-	CG	-	.032	-	.004	-	.008
	LDN - M40 - .748 - W	-	.012	-	CG	-	.040 X .030	-	.006	-	.012

Note : * For Gauge Size information and selection see page 42

EDN : EPOXY DISPENSING NOZZLE

ESEC programmable dispensers are available in Tungsten Carbide or Ceramic Material. The Ceramic version has superior properties in terms of fluid flow, thermal stability for heated system and ease of tip cleaning.



Standard EDN Types					
Tool Style	ØD mm	L mm	Mat'l	ØH mm	ØT mm
EDN	1.5	19	W / C	0.15	0.30
EDN	1.5	19	W / C	0.20	0.35
EDN	1.5	19	W / C	0.25	0.40
EDN	1.5	19	W / C	0.30	0.45
EDN	1.5	19	W / C	0.40	0.55
EDN	1.5	19	W / C	0.50	0.65
EDN	1.5	19	W / C	0.70	0.85
EDN	1.5	19	W	0.90	1.05

CG Option (rect.)

Standard

CG Option (round)

**Other Tip Options
For H=0.15 & H=0.20**

How To Order						
	Tool Style Type - OD - L - Mat'l	ØH	Tip Option	Ø T TL x TW	GD	GW
EXAMPLE:	EDN - 1.5 - 19 - C	- 0.50				
	EDN - 1.5 - 19 - W	- 0.15	- W=0.05			
	EDN - 1.5 - 19 - W	- 0.50	- R			
	EDN - 1.5 - 19 - W	- 0.40	- CG	- 0.85	- 0.09	- 0.18
	EDN - 1.5 - 19 - W	- 0.40	- CG	- 0.90 X 0.70	- 0.08	- 0.16

STAMPING TOOLS INTRODUCTION

Epoxy stamping was used extensively before the appearance of more sophisticated dispensing techniques. Today, stamping tools still represent a viable and inexpensive solution for prototyping, small production series or for very small die size assembly.

The adhesive paste is placed in a rotating cup which surface is leveled by a blade set at the required height. The stamping tool is plunged into the paste and then transfers the collected amount of paste on the target pad.

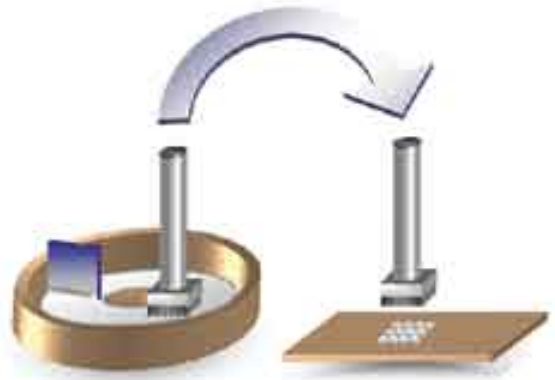

TIP CONFIGURATION

- **REST** Rubber Epoxy Stamping Tool, from die size .051" / 1.30mm and above.
- **SEST** Steel Epoxy Stamping Tool, from die size .006" / 0.15mm and above.

REST : RUBBER EPOXY STAMPING TOOL

The design provides a dot matrix epoxy print out. The layout of the tool pins assures a consistent amount of die attach material to be placed on the pad area.

Three rubber pad patterns are available with different dot diameter and pitch.

- 1) Pad # 3, dot diameter .0118" / 0.30mm , pitch .031" / 0.80mm
- 2) Pad # 5, dot diameter .0197" / 0.50mm , pitch .040" / 1.00mm
- 3) Pad # 6, dot diameter .0236" / 0.60mm , pitch .040" / 1.00mm

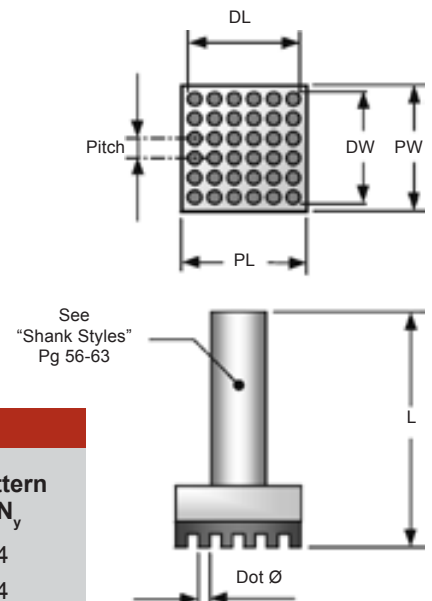
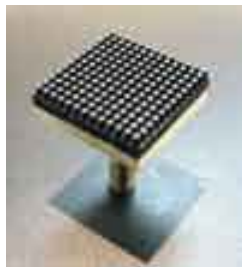

How To Order

	Shank Style & Length	Tip Config.	Pad #	Dot Pattern $N_x \times N_y$
EXAMPLE:	2102 - .625	- REST	- 5	- 4 x 4
	2102 - 16	- REST	- 6	- 8 x 4

HOW TO SELECT THE RIGHT RUBBER EPOXY STAMPING TOOL

Even if empirical experiments give the only true image of the final dispense output, we can approach the desired result by considering the following rule of the thumb.

- The epoxy coverage of the tool chosen must be larger than the die size while the physical Pad pattern PL x PW should be equal or smaller than the die size. For the standard pad layouts, the value PL ,PW, DL and DW are given in the table and can be calculated with the following formula. (N_x = Number of dots in X Axis, N_y = Number of dots in Y Axis)
 Pad size $PL \times PW = (N_x \cdot Pitch) \times (N_y \cdot Pitch)$
 Dot outline $DL \times DW = [(N_x - 1) \cdot Pitch + Dot \varnothing] \times [(N_y - 1) \cdot Pitch + Dot \varnothing]$
- When the die is pressed onto the epoxy layout, enclosed by the dot outline DL x DW , the die attach material will spread out and the epoxy coverage will be extended by approximately :
 + .008"-.012" / 0.20-0.30mm for Pad # 3
 + .020"-.024" / 0.50-0.60mm for Pad # 5
 + .024" / 0.60mm for Pad # 6
- Whenever possible it is advisable to choose a pattern that has closer gap between the dots. For thick layer deposition, it may be necessary to print the same substrate twice.

in inch	Pad # 3		Pad # 5		Pad # 6	
Dot Pattern	Dot Outline DLxDW	Epoxy Coverage	Dot Outline DLxDW	Epoxy Coverage	Dot Outline DLxDW	Epoxy Coverage
2 x 2	.045 x .045	.055 x .055	.060 x .060	.080 x .080	.062 x .062	.084 x .084
2 x 3	.045 x .075	.055 x .085	.060 x .100	.080 x .120	.062 x .102	.084 x .124
3 x 3	.075 x .075	.085 x .085	.100 x .100	.120 x .120	.102 x .102	.124 x .124
3 x 4	.075 x .105	.085 x .115	.100 x .140	.120 x .160	.102 x .142	.124 x .164
4 x 4	.105 x .105	.115 x .115	.140 x .140	.160 x .160	.142 x .142	.164 x .164
4 x 5	.105 x .140	.115 x .150	.140 x .180	.160 x .200	.142 x .182	.164 x .204
5 x 5	.140 x .140	.150 x .150	.180 x .180	.200 x .200	.182 x .182	.204 x .204
5 x 6	.140 x .170	.150 x .180	.180 x .220	.200 x .240	.182 x .222	.204 x .244
6 x 6	.170 x .170	.180 x .180	.220 x .220	.240 x .240	.222 x .222	.244 x .244
6 x 7	.170 x .200	.180 x .210	.220 x .260	.240 x .280	.222 x .262	.244 x .284
7 x 7	.200 x .200	.210 x .210	.260 x .260	.280 x .280	.262 x .262	.284 x .284
7 x 8	.200 x .230	.210 x .240	.260 x .300	.280 x .320	.262 x .302	.284 x .324
8 x 8	.230 x .230	.240 x .240	.300 x .300	.320 x .320	.302 x .302	.324 x .324
8 x 9	.230 x .265	.240 x .275	.300 x .340	.320 x .360	.302 x .342	.324 x .364

in mm	Pad # 3		Pad # 5		Pad # 6	
Dot Pattern	Dot Outline DLxDW	Epoxy Coverage	Dot Outline DLxDW	Epoxy Coverage	Dot Outline DLxDW	Epoxy Coverage
2 x 2	1.1 x 1.1	1.4 x 1.4	1.5 x 1.5	2.0 x 2.0	1.6 x 1.6	2.2 x 2.2
2 x 3	1.1 x 1.9	1.4 x 2.2	1.5 x 2.5	2.0 x 3.0	1.6 x 2.6	2.2 x 3.2
3 x 3	1.9 x 1.9	2.2 x 2.2	2.5 x 2.5	3.0 x 3.0	2.6 x 2.6	3.2 x 3.2
3 x 4	1.9 x 2.7	2.2 x 2.9	2.5 x 3.5	3.0 x 4.0	2.6 x 3.6	3.2 x 4.2
4 x 4	2.7 x 2.7	2.9 x 2.9	3.5 x 3.5	4.0 x 4.0	3.6 x 3.6	4.2 x 4.2
4 x 5	2.7 x 3.6	2.9 x 3.8	3.5 x 4.5	4.0 x 5.0	3.6 x 4.6	4.2 x 5.2
5 x 5	3.6 x 3.6	3.8 x 3.8	4.5 x 4.5	5.0 x 5.0	4.6 x 4.6	5.2 x 5.2
5 x 6	3.6 x 4.3	3.8 x 4.6	4.5 x 5.5	5.0 x 6.0	4.6 x 5.6	5.2 x 6.2
6 x 6	4.3 x 4.3	4.6 x 4.6	5.5 x 5.5	6.0 x 6.0	5.6 x 5.6	6.2 x 6.2
6 x 7	4.3 x 5.1	4.6 x 5.3	5.5 x 6.5	6.0 x 7.1	5.6 x 6.6	6.2 x 7.2
7 x 7	5.1 x 5.1	5.3 x 5.3	6.5 x 6.5	7.1 x 7.1	6.6 x 6.6	7.2 x 7.2
7 x 8	5.1 x 5.8	5.3 x 6.1	6.5 x 7.5	7.1 x 8.1	6.6 x 7.6	7.2 x 8.2
8 x 8	5.8 x 5.8	6.1 x 6.1	7.5 x 7.5	8.1 x 8.1	7.6 x 7.6	8.2 x 8.2
8 x 9	5.8 x 6.7	6.1 x 7.0	7.5 x 8.5	8.1 x 9.1	7.6 x 8.6	8.2 x 9.2

Metallic stamping tools are used for small to medium die sizes. The tip has a specific shape depending on the range of recommended die size and is adaptable to all shank types :

- **DAUB** tip : for die size less than .012" / 0.30mm
- **ROUND** tip : for die size less than .032" / 0.80mm
- **RECTANGULAR** tip : for die size between .024" / 0.60mm and .040" / 1.00mm
- **STAR** tip : for die size between .040" / 1.00mm and .235" / 6.00mm
- **GRID** tip : for die size larger than .100" / 2.54mm
- **FRAME** tip : for device size larger than .100" / 2.54mm
- **FRAME-GRID** tip : for device size larger than .100" / 2.54mm

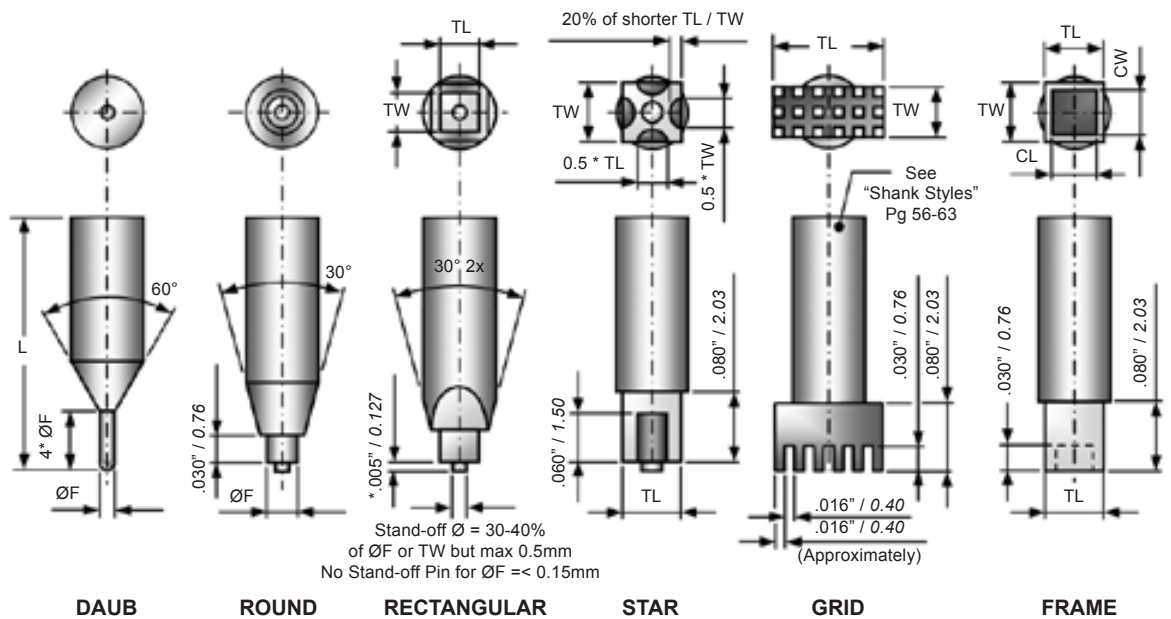

The small stand off allows for consistent amount of epoxy to be picked up and transferred. Note: *Standard height is .005" / 0.127mm and limited to 50% of stand-off when shorter size of TL, TW or $\varnothing F$ is less than .030" / 0.80mm.



How To Order

	Shank Style & Length	-	Tip Config.	-	Dimensions $\varnothing F / TL \times TW$	-	Grid Frame : $N_x \times N_y$ $CL \times CW$
EXAMPLE:	2102 - .625	-	SEST-DAUB	-	.010		
	MC	-	SEST-ROUND	-	1.2		
	2138	-	SEST-STAR	-	.080 x .080		
	2102-16	-	SEST-GRID	-	13.5 x 13.5	-	8 x 8
	2141-25	-	WEST-FRAME	-	7.20 x 6.50	-	6.80 x 6.10

SEST : SPRING LOADED STEEL EPOXY STAMPING TOOLS

A spring-loaded stamping tool version is offered on two common threaded shank holders.

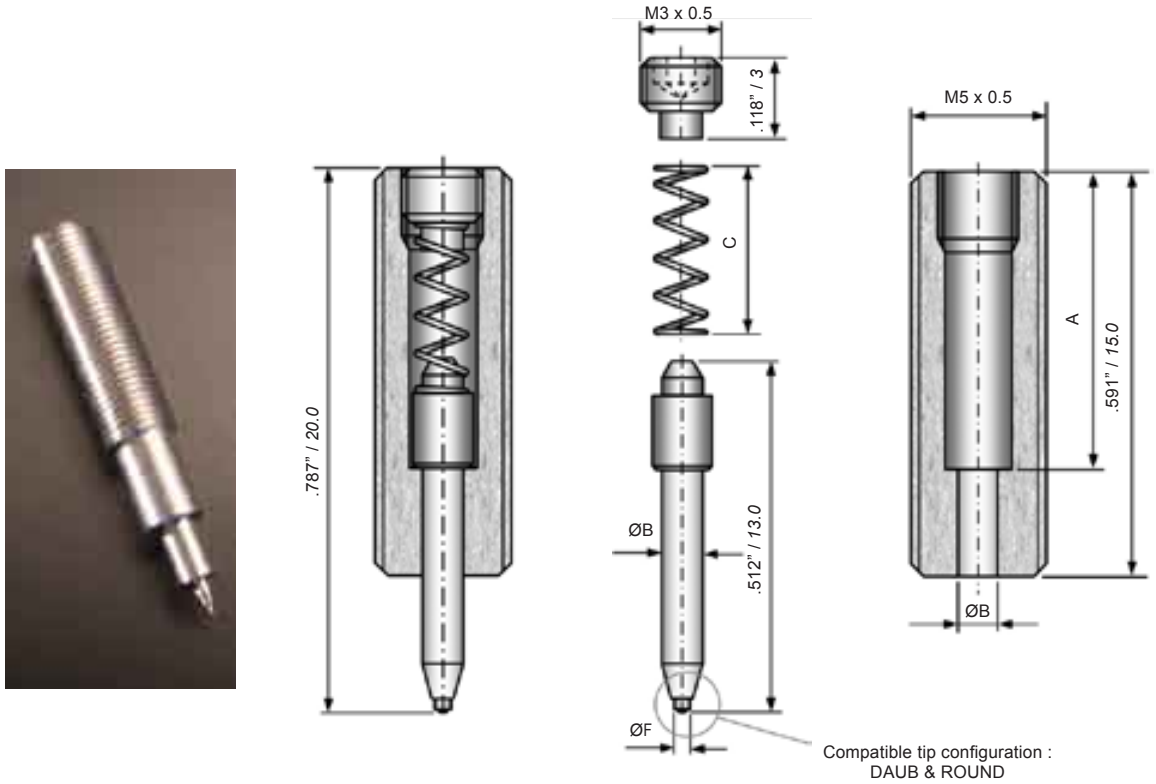

DISPENSING & STAMPING TOOLS

How To Order : SEST only			
	Shank Style & Length	Tip Config.	Dimensions $\varnothing F$
EXAMPLE:	ASM - 13	SEST-DAUB	0.20
	AMI - 13	SEST-ROUND	.003

How To Order : Accessories			
	Shank Style	Item	Remark
EXAMPLE:	ASM-SEST	Tension Screw	
	ASM-SEST	Holder	
	AMI-SEST	Spring	

Dimensions			
	A mm	B mm	C mm
ASM	11.0	1.47	6.50
AMI	9.0	1.60	4.50

Dimensions			
	A inch	B inch	C inch
ASM	.433	.058	.256
AMI	.354	.064	.177

PUN : PUSH-UP NEEDLES

Die Push-Up needles or Die Ejector Pins are used in automatic die bonding machines. The Push-Up Needles push up the die through the expanding PVC adhesive film allowing a collet or pick-up tool to seize the die. The smooth, highly polished taper and small angle allow gentle penetration in the film with little movement of the film. Depending on the size of the die, 1 or more needles are required where reproducibility from needle to needle is critical.

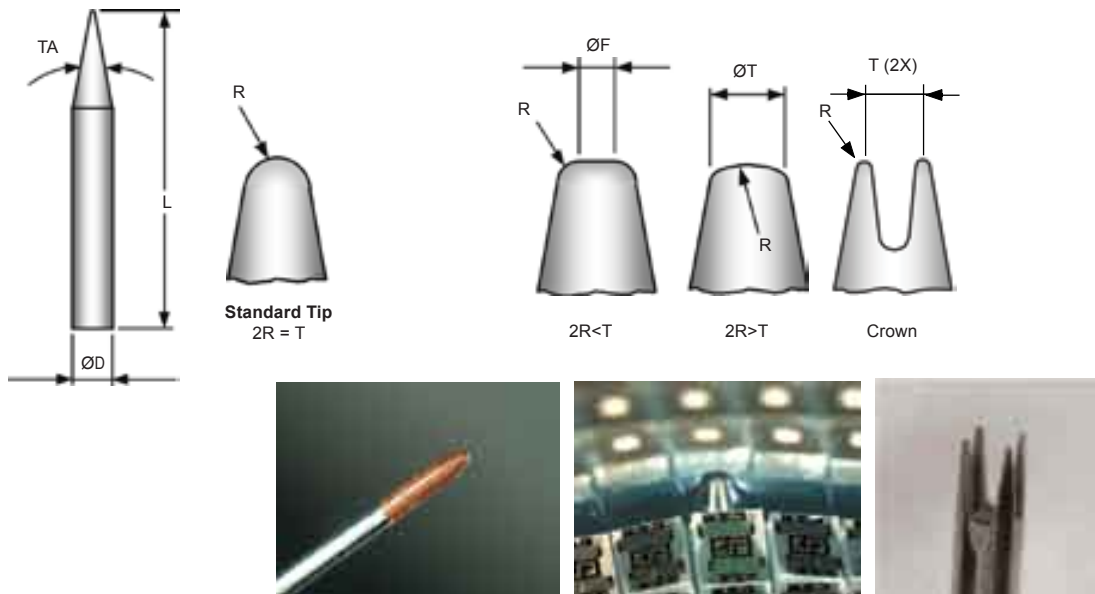

Standard Push-Up Needle										
Tool Style	Ø D mm	L mm	Taper Angle	R µm	Fits Die Bonder	Tool Style	Ø D inch	L inch	Taper Angle	R inch
PUN	0.70	10.0	10/15°	25		PUN	.0275	.394	10/15°	.001
PUN	0.70	12.0	10/15°	25	Esec	PUN	.0275	.472	10/15°	.001
PUN	0.70	14.3	10/15°	25	AMI	PUN	.0275	.562	10/15°	.001
PUN	0.70	15.0	10/15°	25	Kaijo	PUN	.0275	.590	10/15°	.001
PUN	0.70	17.0	10/15°	25	ASM. Delvotec. Foton. Muehlbauer Datacon	PUN	.0275	.669	10/15°	.001
PUN	0.70	18.0	10/15°	25	Esec	PUN	.0275	.709	10/15°	.001
PUN	0.70	19.0	10/15°	25	Alphasem . AMI	PUN	.0275	.750	10/15°	.001
PUN	0.66	14.0	10/15°	25	Shinkawa	PUN	.026	.551	10/15°	.001
PUN	0.66	18.0	10/15°	25		PUN	.026	.709	10/15°	.001
PUN	0.66	18.0	15°	12		PUN	.026	.709	15°	.0005

How To Order							
Tool Style	Mat'l	Ø D	L	TA	R	Option	Crown - T
EXAMPLE:	PUN	- 0.70mm	- 17mm	- 10DG	- 25MIC	-	-
	PUN	- HSS	- 0.70mm	- 18mm	- 15DG	- 25MIC	- F= 25MIC
	PUN	-	- 0.70mm	- 17mm	- 10DG	- 300MIC	- T=80-100MIC
	PUN	- W	- 0.70mm	- 17mm	- 10DG	- 25MIC	- Crown - 0.46mm
	PUN	- HTV	- 0.70mm	- 18mm	- 15DG	- 150MIC	-

- Standard and default material is W (No need to specify)
- Optional HSS (High Speed Steel) is also available to address tip fragility issue.
- Optional Plastic Tip to minimize the risk of back die cracking.

DST : DIE SHEAR TOOL

The Die Shear Tool (DST) is a tool attachment for the shear test equipment used for shearing die from a substrate to test its adhesive or shear strength. It is recommended that the tool face width "FW" should always be longer (>20%) than the die side in contact with the shear tool. The die reflection from the mirror finished of the tool face will further aid operator to position the die within the tool face width.

Material available: W (Tungsten carbide) and HSS (High Speed Steel)

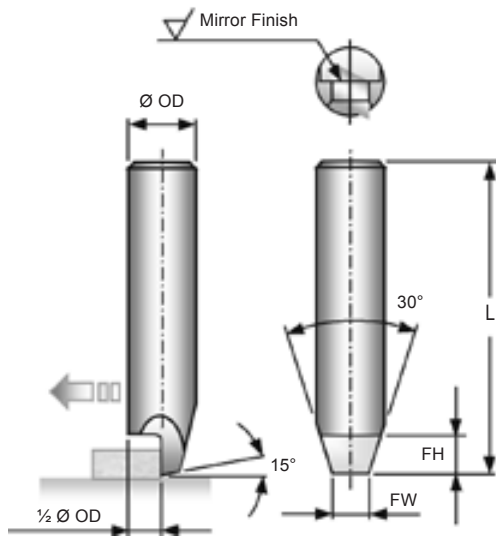

DST (Standard)

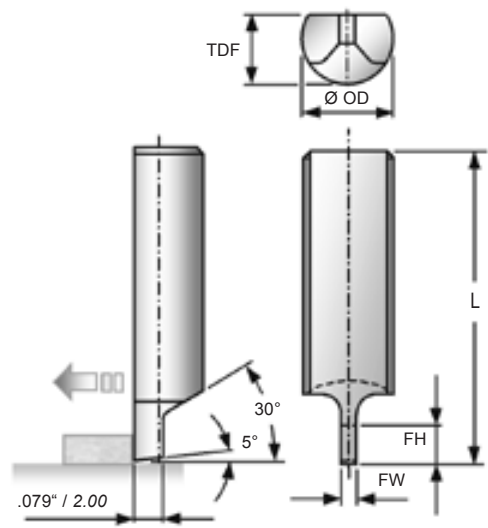

DST2 (Special)



How To Order

	Tool Style	Outer Ø OD	L	Mat'l	FW	FH	TDF	Option
EXAMPLE:	DST	.1875"	.760"	W	.097"	.120"		
	DST2	.250"	.730"	HSS	.040"	.118"	.190"	

SPANK : SPANKER TOOL

The Spanker Tool is used on soft solder die bonding, which is required for power devices. Soft solder makes use of eutectic point between two or more alloy elements: Tin/Gold, Tin/Lead/Silver. Pre-cut in reel needs to be positioned on the bond pad by pick and place machine or through dispensing of molten solder. The tool is spanked over the adhesive to fill the cavity form. High process temperature and pressure are needed during die bonding.

Material available: W (Tungsten carbide) or MS (Alloy Steel)

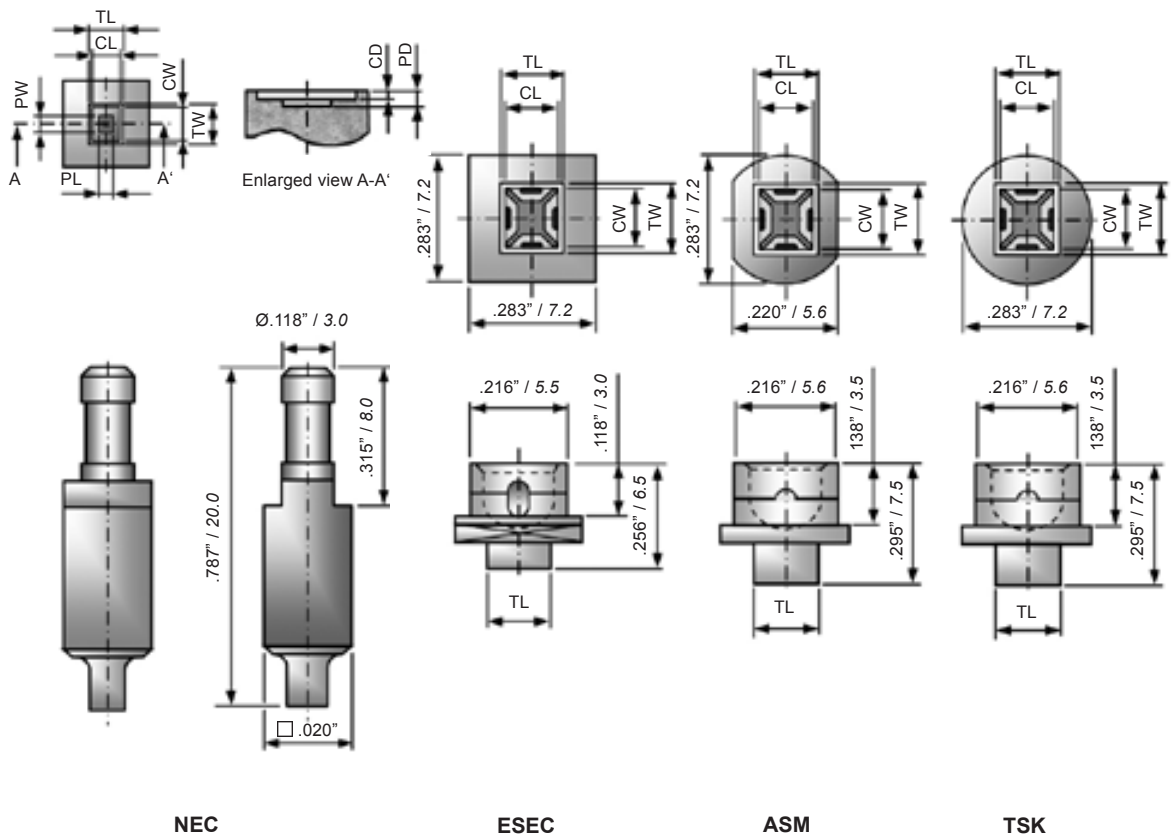

How To Order								
Tool Style	Body Style	L	Mat'l	TL x TW	CL x CW	- NEC: (PL x PW-CD-PD) ESEC07: (Front Hole)*		
EXAMPLE:	SPANK - NEC	- 20.0	- W	- 2.0 x 2.3	- 1.8 x 2.1	- 0.8 x 1.0	0.05	0.07
	SPANK - ESEC07	- 6.50	- MS	- 3.8 x 3.5	- 3.5 x 3.2	- H=0.25		
	SPANK - TSK	- 7.50	- MS	- 5.2 x 4.8	- 4.9 x 4.5			

Notes : TL, CL or PL are not necessarily larger than TW, CW or PW
On ESEC bonder a front pin hole is necessary for SSD but none for MPPM process

NC: NEEDLE CAP
NH: NEEDLE HOLDER

Needle cap and needle holder are used together to accomplish function of pick up die through expanding PVC adhesive film with eject needle installed .Various configurations which have either single needle or multi-needle designs are applicable for wide range die size .



Set for ASM 829



NC for ASM 809



Set for ESEC 2008













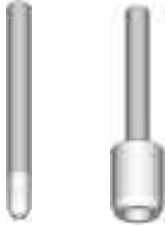

















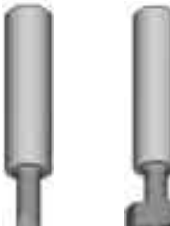

Several needle configurations are possible based on the die dimensions. To get a recommended design, please provide the requested Tool Style together with the bonder Model and the die size x * y.

How To Order











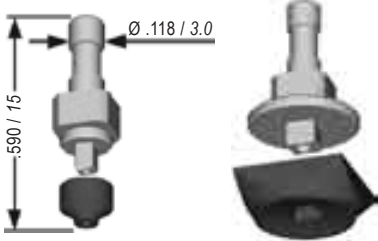



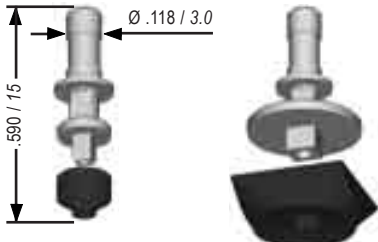



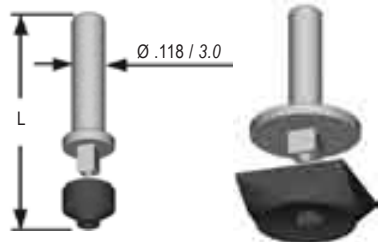

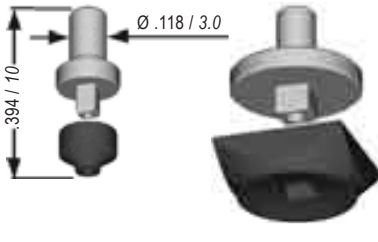

	Tool Style	-	Model	-	Drawing Number
EXAMPLE:	NH	-	ASM829	-	DD-MS-0172-S1
	NC	-	ASM809	-	DD-MS-0097
	NH	-	ESEC2008	-	DD-MS-0111-S8
	NC	-	ESEC2008	-	DD-MS-0152-S3

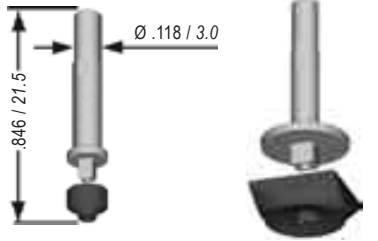



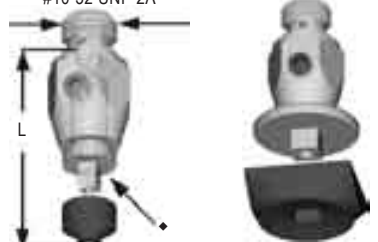















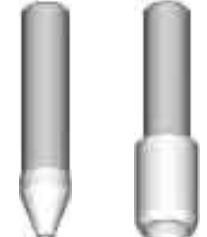









SHANK STYLES USED ON COMMON DIE ATTACH BONDERS

SHANK STYLE	SPECIFY L (inch/mm)	PCTR / FCTR / (H)CTR / (H)RTR A / B C / D	RPCT	ST	SC
2101 Esec 2005/2006 Dr.Tresky flip station West Bond	.315 / 8 .315 / 8 .625 / 16				
2102 Royce Instruments ASM Datacon / Viking Foton / Häcker / Hilbond Delvotec / Air-Vac Muehlbauer / Amadyne K&S6300/6900 Laurier DS x000 / K&S 6490 SEC	.315 / 8 .550 / 14 .625 / 16 .625 / 16 .625 / 16 .625 / 16 .750 / 19 1.25 / 32				
2102A1 Shinkawa	--				N/A
2102M2 Universal	--				
2112 Assembly Techn. ESC 2143 AMI ESC	.437 / 11.1 .437 / 11.1 .375 / 9.5 .375 / 9.5				N/A
2134 ASM 809	--				











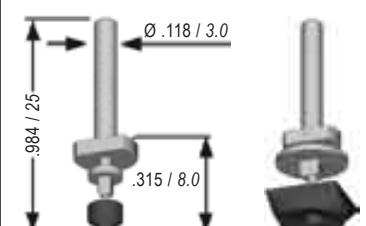



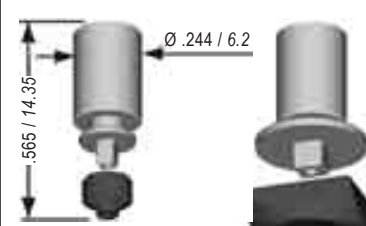

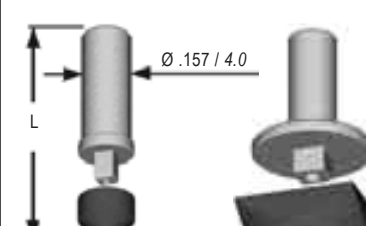



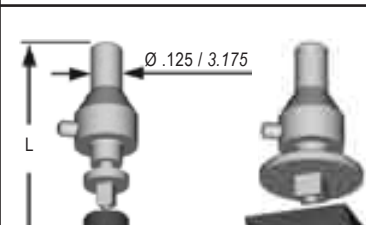

2151-CT	CT Small / Large	RT Small / Large	IP/IPIR/IPNC IPRC/CH/PL	SEST	REST
N/A					
					
N/A					
					
N/A					
				N/A	N/A

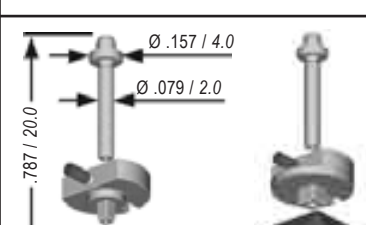



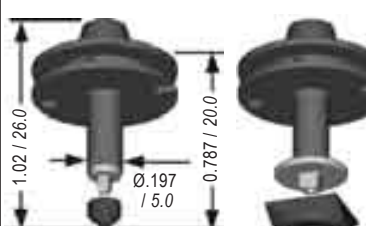





















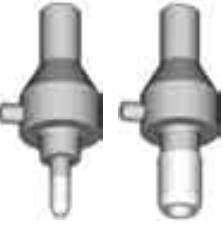
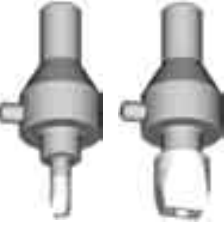
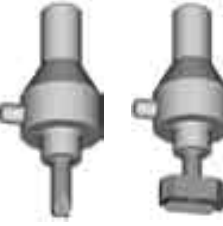

SHANK STYLES USED ON COMMON DIE ATTACH BONDERS

SHANK STYLE	SPECIFY L (inch/mm)	PCTR / FCTR / (H)CTR / (H)RTR A / B C / D	RPCT	ST	SC
2138 Shinkawa	--				
2138G Alphasem Easyline	--				
2141 - Dr. Tresky	625 / 16 .984 / 25				
2141M KME	--				N/A
GS Alphasem Swissline	--				
HG1.. / HG2.. Palomar (Hughes) HG1S / HG2S = Set Screw HG1S3 / HG2S3 = 3 Screws HG1P / HG2P = Press Fit HG1B / HG2B = Braze Fit ♦ 2101-.437 for HG1...500 ♦ 2101-.687 for HG1...750 ♦ 2102-.437 for HG2...500 ♦ 2102-.687 for HG2...750 To be ordered separately	.500 / 12.7 .750 / 19.0 Deep Access Deep Access	#10-32 UNF-2A 			

2151-CT	CT Small / Large	RT Small / Large	IP/IPIR/IPNC IPRC/CH/PL	SEST	REST
				N/A	N/A
					
					
N/A					
				N/A	N/A
					

SHANK STYLES USED ON COMMON DIE ATTACH BONDERS

SHANK STYLE	SPECIFY L (inch/mm)	PCTR / FCTR / (H)CTR / (H)RTR A / B C / D	RPCT	ST	SC
TSK Toshoko	--	 <p> $\text{Ø} .118 / 3.0$ $.984 / 25$ $.315 / 8.0$ </p>			
044C Quad APS-1	--	 <p> $\text{Ø} .244 / 6.2$ $.565 / 14.35$ </p>			N/A
574 Ismeca 574A (notch on shank) Amicra (SDB1000 / ADB2000)	$.551 / 14$ $.787 / 20$ $.984 / 25$ $1.18 / 30$ $1.18 / 30$	 <p> $\text{Ø} .157 / 4.0$ L </p>			
1059 (no Dowel Pin) 1059D (with Dowel Pin) MRSI 505	$.688 / 17.5$ $.875 / 22.2$	 <p> $\text{Ø} .125 / 3.175$ L </p>			
MC ESEC Micron 2 ESEC Micron 5003	--	 <p> $\text{Ø} .157 / 4.0$ $\text{Ø} .079 / 2.0$ $.787 / 20.0$ </p>			
MC26 (Fixed Inserted Shank) MC26A (with Spring Assembly) Available only with ★ ESEC Micron 2 ESEC Micron 5003	--	 <p> $1.02 / 26.0$ $\text{Ø} .197 / 5.0$ $.787 / 20.0$ </p>	★ 	★ 	★ 













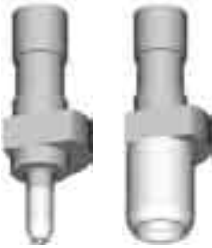

2151-CT	CT Small / Large	RT Small / Large	IP/IPIR/IPNC IPRC/CH/PL	SEST	REST
					
N/A					
					
					
N/A		N/A	N/A	N/A	N/A
	★ 	★ 		★ 	

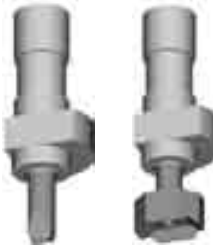
SHANK STYLES USED ON COMMON DIE ATTACH BONDERS

SHANK STYLE	SPECIFY L (inch/mm)	PCTR / FCTR / (H)CTR / (H)RTR A / B C / D	RPCT	ST	SC
MC26AR (anti-rotation spring assembly) ESEC Micron 2 ESEC Micron 5003	--				N/A
DBH3 ESEC late 2006 ESEC 2007 ESEC 2008	--				N/A
VW Vacuum Wand	--				
GSM Universal	--				

Nozzles For Universal Machines

Other Various Shank Types and Tips Consult your nearest SPT office for details.					
---	--	--	--	--	--

2151-CT	CT Small / Large	RT Small / Large	IP/IPIR/IPNC IPRC/CH/PL	SEST	REST
N/A			N/A		
				N/A	N/A
N/A				N/A	N/A
				N/A	N/A

DIE BONDING TOOLS DESIGN ENQUIRY FORM

SPT Roth Ltd
 (Switzerland)
 E-mail : info@sptroth.com
 Fax : ++ 41 32 387 80 88

Small Precision Tools Inc
 (California, USA)
 E-mail : info@sptca.com
 Fax : 1 707 778 2271

SPT Asia Pte Ltd
 (Singapore)
 E-mail : info@sptasia.com
 Fax : 65 6250 2725

Small Precision Tools (Phil) Corp
 (Philippines)
 E-mail : info@sptphil.com
 Fax : 632 531-5780

Small Precision Tools Co Ltd
 (China)
 E-mail : info@sptchina.com
 Fax : 86 510 8516 5233

SPT Japan Co. Ltd
 (Japan)
 E-mail : info@sptjapan.com
 Fax : +81 45 470 6755

REQUESTOR DATA			
Name :	_____	Date :	_____
Designation :	_____	Telephone :	_____
Company :	_____	Contact Ext ⁿ :	_____
Location :	_____	Fax Number :	_____
Department :	_____	Buyer's Name :	_____

This information is needed for Die Bonding Tool design requirement. For your custom design, please fax to our office your detailed drawing together with this furnished format.

PACKAGE INFORMATION					
Package <input type="checkbox"/> PDIP <input type="checkbox"/> PLCC <input type="checkbox"/> SOIC <input type="checkbox"/> Others (please specify) : _____					
Type : <input type="checkbox"/> TSOP <input type="checkbox"/> QFP <input type="checkbox"/> COB _____					
Die Dimensions (mils)			Substrate Size (mils)		Others
Length	Width	Thickness	Length	Width	

EPOXY INFORMATION		
Manufacturing Part Number	Material Description	Viscosity

EPOXY CRITERIA					
Spec. Limits	Underneath Criteria		Fillet Criteria		Other Criteria
	% Coverage	Thickness (mils)	Overflow (mils)	Height (mils)	
Maximum					
Minimum					

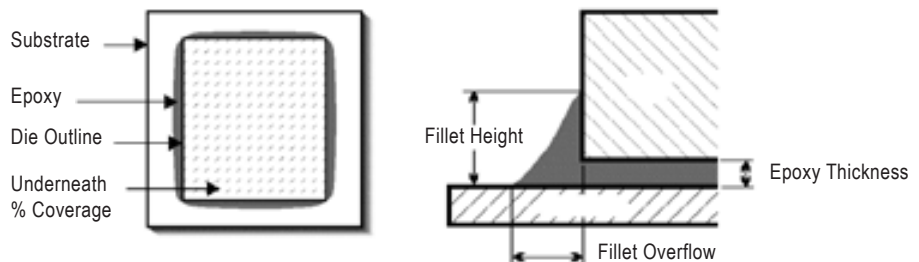

OTHER INFORMATION	
Die Attach Equipment / Model : _____	
Epoxy Reservoir : <input type="checkbox"/> _____ cc Syringe Container <input type="checkbox"/> Others (please specify) : _____	
Currently using other dispensing tools? <input type="checkbox"/> No <input type="checkbox"/> Yes	
If yes, please specify Manufacturing Part Number / Needle Gauge : _____ / _____	

Other EDT design considerations : _____

Revised 8/08-1

SPT Roth Ltd

Werkstrasse 28, CH-3250 Lyss, Switzerland

Tel : ++ 41 32 387 80 80

Fax : ++ 41 32 387 80 88

E-Mail : info@sptroth.com

Small Precision Tools Inc

1330 Clegg Street, Petaluma, CA 94954, USA

Tel : 1 707 765 4545

Fax : 1 707 778 2271

E-Mail : info@sptca.com

SPT Asia Pte Ltd

970 Toa Payoh North, #07-25/26, Singapore 318992

Tel : 65 6253 5577

Fax : 65 6250 2725

E-Mail : info@sptasia.com

Small Precision Tools (Phil) Corp

35 Libertad Street, Mandaluyong City 1550, Philippines

Tel : 632 533-7067

Fax : 632 531-5780

E-Mail : sales@sptphil.com

Small Precision Tools Co Ltd

A2 Building, Liyuan Economic Development Zone,
Wuxi, Jiangsu, P.R.China 214072

Tel : 86 510 8516 1968

Fax : 86 510 8516 5233

E-Mail : info@sptchina.com

SPT Japan Co. Ltd

901, 2-5-2, Shin-Yokohama, Kohoku-ku,
Yokohama-shi, Kanagawa, 222-0033 Japan

Tel: +81 45 470 6288

Fax: +81 45 470 6755

E-Mail: info@sptjapan.com

www.smallprecisiontools.com

